

## **The Influence of Principal's Leadership, Teacher Performance And Internal Quality Assurance System in Improving The Quality of Education in Vocational High School**

**Muhammad Abdul Rahman**  
Universitas Ahmad Dahlan  
muhabdul\_rahman@yahoo.co.id

**Achadi Budi Santosa**  
Universitas Ahmad Dahlan  
budi.santosa@mp.uad.ac.id

**Hotmaulina Sihotang**  
Universitas Kristen Indonesia  
hotmaulina.sihotang@uki.ac.id

### **ABSTRACT**

*This study aims to determine the extent of the influence of the Principal Leadership, Teacher Performance, and the internal quality assurance system either partially or simultaneously on quality improvement at SMK Muhammadiyah 1 Bambanglipuro and SMK Negeri 1 Pandak. The study population was all teachers in the two schools, each of which was taken 35 teachers as a sample. Data collection was carried out by observation and questionnaires. Data were tested using validity, reliability, linearity, multicollinearity, and heteroscedasticity tests. Data analysis was then performed using multiple regression analysis, t-test, F test, and determination coefficient. The results show that; first, the school principal leadership, teacher performance, and internal quality assurance systems have a significant effect on improving the education quality of SMK Muhammadiyah 1 Bambanglipuro, where the contribution given is 23.40% and the regression equation obtained is  $\hat{Y} = 3,138 + 0,106X1 + 0,109X2 + 0,086X3$ , while the principal's leadership, teacher performance, and internal quality assurance system together have a significant effect on improving the education quality at SMK N 1 Pandak, where the contribution is 26.50% and the regression equation obtained is  $\hat{Y} = 3,378 + 0,150X1 + 0,162X2 + 0,049X3$ . Second, there is a difference in quality improvement, which shows that there are significant differences in quality between SMK Muhammadiyah 1 Bambanglipuro and SMKN 1 Pandak.*

**Keywords:** *Principal Leadership, Teacher Performance, Internal Quality Assurance System, Education Quality Improvement*

---

### **Article Info**

Received date: 25 Agustus 2020

Revised date: 15 Desember 2020

Accepted date: 15 Desember 2020

### **INTRODUCTION**

Various empirical facts have shown us that human resources are quite important

factors to accelerate the achievement of the progress of a nation. No matter how large the natural resources, capital, and infrastructure

are, ultimately in the hands of reliable human resources lies the progress to be achieved. In Indonesia, National development is an effort of the community is continuously improving human quality based on national capabilities, utilizing science and technology by minimizing existing obstacles to face the challenges of global progress. In line with the objectives of this study, it is recognized that formal education is the best way to win competitions, promote national capabilities, be able to sell products effectively and gather resources, and also as a foundation for rapid progress in the socio-economic and national political environment, and encourage the emergence of professional leaders. However, quality education will pave the way for future ideals. (Mosha, H., 2018; Garira, E., Howie, S., & Plomp, T., 2019; Ullah, M., Latif, K. F., Farooq Sahibzada, U., & Latif, I., 2019; Ahmad, S., & Batool, A., 2020; Moscoviz, L., & Bélanger, J., 2019).

The improvement in quality of education in schools is influenced by several factors, especially are human resource factors and education management (Kaufman, B. E., 2019; Mukhopadhyay, M., 2020; Daly, A., Moolenaar, N., Tuytens, M., & Devos, G., 2019; Badri, M., Almazroui, K., Al Rashedi, A., & Yang, G., 2019; DU, J. C., 2019). Human resource factors included the principal and teachers. In an effort to improve the quality of education, the principal must carry out his role as the principal and must be able to maximize all the potential he has to carry out programs and school development. Classifies the roles of principals into three categories, namely: leadership roles, managerial roles, and the role of curriculum developers and learning (Huston, C. J., & Marquis, B. L., 2009; Lunenburg & Ornstein, 2011; Xiong, J., Wu, R., Xu, Z., Ma, Q., & Li, Y. 2020). Because a manager's important task is to direct and motivate human resources, the principal must have control over his subordinates in carrying out quality improvement programs that will be

implemented by the school. The head of the school as a manager is assigned as a planner, organizer, leader, and a controller (Sihotang, H., & Nadeak, B., 2017). According to Wahjosumidjo (2013), there are eight kinds of functions of a manager that need to be carried out in an organization, namely that managers; 1) work with and through others, 2) take responsibility and be accountable, 3) with limited time and resources able to deal with various problems, 4) think realistically and conceptually, 5) as a mediator, 6) as a politician, 7) as a diplomat, 8) as a difficult decision-maker. The role of the principal as an educator includes two things namely the target or to whom the behavior as an educator is directed (Mitchell, D., & Sutherland, D., 2020; Boies, K., & Fiset, J., 2019; Holdaway, A. S., Owens, J. S., Serrano, V. J., Hustus, C., & Mixon, C. S., 2019) While the second, namely how its role as an educator is carried out. There are three main target groups, namely the teachers or other functional staff, administrative staff, and groups of students. As an educator, the principal must be able to direct the teachers or functional staff, administrative staff, and groups of students for implementing programs held at school (Wahjosumidjo, 2013; Davis, B. W., & Bowers, A. J., 2019; Hardwick-Franco, K. G., 2019, Clifton, J., & Jordan, K., 2019).

In addition, the role of the teacher is also very much needed so that quality education can be achieved (Steinmayr, R., Cimpian, A., Weidinger, A. F., & Heyder, A., 2020; Eren, A., & Çetin, G., 2019). Teachers are the pioneer because they interact most directly with students. If teachers can perform their duties to the fullest, the improvement within the quality of education can be achieved. An absolute requirement that must be done in an effort to improve the achievement of educational standards is to improve the quality of teachers in education units. The effort to improve teacher quality requires adequate mechanisms,

teachers need to be developed based on a comprehensive assessment to produce an accountable conceptual and empirical basis (Fitriyah, I., Santosa, A.B., 2020; Mulyasa, 2013; Merriam, S. B., & Baumgartner, L. M. 2020; Knollmann, M., Reissner, V., & Hebebrand, J., 2019; DiStefano, L. J., Scarneo, S. E., Stearns, R. L., Denegar, C. R., Mihalik, J. K., & Casa, D. J., 2019). The teacher guarantee activity is carried out through a certification system and teacher competency test. 4 competencies that must be possessed by a teacher, namely (1) abilities in the pedagogical field, (2) personality abilities, (3) social abilities, and (4) professional skills (Mulyasa, 2013; Sihotang, H., 2020; Koskinen, Tuomikoski, AM, Koivula, M., Koskimäki, M., C., Mikkonen, K., Lähteenmäki, ML, & Sjögren, T., 2020; Zhong, HF, Keller-Schneider, M., & Yeung, USA, 2020). These competencies are used as a base for teachers in organizing the teaching-learning process in the classroom, as well as pedagogical teachers everywhere. (Istiningsih, E., Santosa, AB, 2020), according to the suitability in the planning of learning to be carried out in schools, evaluation of learning outcomes, and student development to actualize the various potentials, they need to improve student abilities.

To keep the quality of education under control, a clear education guarantee system is needed. The guarantee system controls managerial education management and academic learning processes. As mentioned in the Minister of Education and Culture Regulation No. 28 of 2016 which regulates the quality assurance system of primary and secondary school education. Quality assurance of education is a systematic, integrated and ongoing mechanism to ensure that the entire

process of providing education is in accordance with quality standards (Simkin, A., Mozhaeva, T., & Proskurin, A., 2019; Mukhopadhyay, M., 2020; Kim, J., 2018), while the quality assurance system at the elementary and secondary education level is an integrated part consisting of school organizations, policies, and processes that regulate all activities to improve the quality of primary and secondary education related to each other systematically, planned, and continuously.

Educational input factors and education management process factors are influencing the improvement of the quality of education. Educational input is everything that must be available because it is needed for the process to take place. The components and resources of schools consist of people (man), funds (money), facilities and infrastructure (material) and regulations (policy). Human resources (man) is a very important factor to support the success of school achievement. Human resources in school management include; a) The principal is a teacher who gets an additional assignment as a principal. (2003 National Education System Chapter II Article 2). b) Teacher, under Law No. 14 of 2005 In Chapter I Article 1 it is stated that the teacher is a professional educator whose duties include directing, training, teaching, guiding, educating, and evaluating students. c) The administrative staff is school, operational support staff. d) Students, students as students are one input that also determines the success of the education process. Acceptance of students must be done with clear, transparent, and accountable criteria. (Quynh, N. L. T., & Huu, C. N., 2020).

### **Conceptual framework**

The conceptual framework of the study is described in the following scheme.

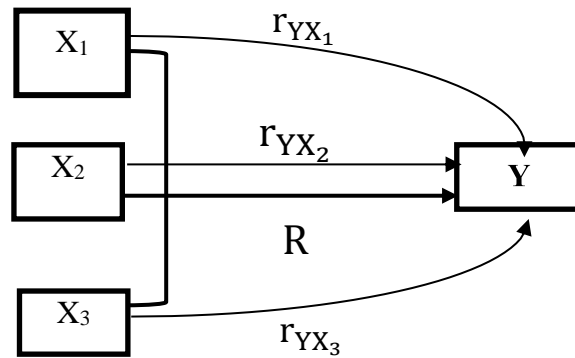

Figure 1. The conceptual framework

**Hypothesis**

Ha<sub>1</sub> = There is a significant influence between Teacher Performance, school principal leadership, and the Internal Quality Assurance System on improving the quality of education in SMK Muhammadiyah 1 Bambanglipuro and SMK N 1 Pandak

Ha<sub>2</sub> = There is a significant difference in improving student learning achievement in class XI of SMK Muhammadiyah Bambanglipuro and SMK N 1 Pandak.

**METHODS**

This study was conducted in SMK Muhammadiyah 1 Bambanglipuro and 35 teachers at SMK N 1 Pandak. This study uses a quantitative approach (Marchand, G., Mc.Crudden, M. T., & Schutz, P., 2019; Ishtiaq, M., 2019; Creswell, JW, 2014). This research was conducted by survey method, the sampling was taken by simple random sampling, from the population randomly without regard to strata in the population. Samples taken included 35 teachers from SMK Muhammadiyah 1

Bambanglipuro and 35 teachers at SMK N 1 Pandak. To obtain the data, we used primary data collection techniques through a questionnaire, namely by spreading questions to respondents who were sampled, where respondents chose one of the answers provided. The answers to the questionnaire are using the Likert scale method. The analytical model used in this study is the multiple linear analysis. Hypothesis tests were done through partial tests, simultaneous tests, and coefficient of determination tests (Yoda, T. C., 2019; Hafidhah, R. N., & Martono, S. 2019).

**RESULT**

The validity and reliability results can be seen in the following table:

**Principal's leadership**

The results of the validity test on the principal's leadership variables indicate that the indicators for each variable meet the validity requirements, namely,  $r_{count} > r_{table}$ . Therefore, this indicator can be used to measure the variables of this study. The following table 1 shows the results of reliability testing.

Table 1. Principal's leadership reliability test

Variabel	Cronbach's Alpha	r <sub>tabel</sub>	Decision
Principal's leadership	0,955	0,349	Reliabel

Based on the table 1, because the Alpha value is greater than r<sub>table</sub> (Alpha > r<sub>table</sub>), which is 0.955 > 0.3494, it is stated that all data on the

principal's leadership instruments are consistent or reliable.

**Teacher Performance**

The results of the validity test on the teacher performance variable indicate that the indicators on each variable meet the validity

requirements. Table 2 below shows the results of the variable reliability test of teacher performance instruments.

**Table 2. Teacher performance reliability test**

Variabel	Cronbach's Alpha	r <sub>tabel</sub>	Decision
Teacher Performance	0,929	0,349	reliabel

Based on the table 2 because the Alpha value is greater than r<sub>table</sub> (Alpha > r<sub>table</sub>) which is 0.929 > 0.3494, it is stated that all teacher performance instrument data is consistent or reliable.

quality assurance system variables indicate that the indicators on each variable meet the validity requirements, namely r<sub>count</sub> > r<sub>table</sub>. Therefore, these indicators can be used to measure the variables of this study. Reliability testing can be seen in the following table 3.

**Internal Quality Assurance System (IQA).**

Based on the processed data, it is known that the validity test results on the internal

**Table 3. Internal Quality Assurance System reliability test**

Variabel	Cronbach's Alpha	r <sub>tabel</sub>	Decision
Internal Quality Assurance System	0,975	0,349	Reliabel

Based on the table 3 because the Alpha value is greater than r<sub>table</sub> (Alpha > r<sub>table</sub>) which is 0.975 > 0.3494, it is stated that all internal quality assurance instruments data are consistent or reliable.

variable improvement in the quality of education indicate that the indicators for each variable have fulfilled the validity requirements, namely r<sub>count</sub> > r<sub>table</sub>. Therefore, these indicators can be used to measure the variables of this study. Table 4 below shows the results of reliability testing.

**Education Quality Improvement**

From the data processed, it is known that the results of the validity test on the

**Table 4. Educational quality improvement reliability test**

Variabel	Cronbach's Alpha	r <sub>tabel</sub>	Keputusan
Education Quality Improvement	0,841	0,349	Reliabel

Based on the table 4 because the Alpha value is greater than r<sub>table</sub> (Alpha > r<sub>table</sub>) which is 0.841 > 0.3494, it is stated that all data instruments for improving the quality of education are consistent or reliable.

regression analysis was used with the help of the SPSS program version 20.0, as contained in the following table 5

**Table 5. Multiple regression**

The data in table 5 shows that the value of multiple linear regression constants is 3.138, with the regression coefficient value of the principal's leadership variable 0.106, the value of the multiple linear regression coefficients of teacher performance variables is 0.109, and the regression coefficient of the internal quality

**Hypothesis Testing at SMK Muhammadiyah 1 Bambanglipuro:**

**Multiple Linear Regression Models**

To see the influence between the principal's leadership, teacher performance and the internal quality assurance system of the model school on improving quality at SMK Muhammadiyah 1 Bambanglipuro, multiple

assurance system variable's value is 0.086. Then by referring to the formula of the multiple linear regression equation  $\hat{Y} = a + b_1.X_1 + b_2.X_2 + b_3.X_3$ , the multiple linear regression equation can be formed as follows:  $\hat{Y} = 3,138 + 0,106.X_1 + 0,109.X_2 + 0,086.X_3$

The multiple linear regression equation above has the following implications;

- a. If the principal's leadership variables, teacher performance, and internal quality assurance systems are absent ( $X_1, X_2, X_3 = 0$ ), then the improvement in the quality of education is at 3,138
- b. If the addition of one point of the principal's leadership variable is carried out it will improve the quality of education by 0.106 times.

- c. If the addition of one point of the teacher performance variable is done it will improve the quality of education by 0.109 times.
- d. If one point is added to the variable internal quality assurance system, it will improve the quality of education by 0.086 times.
- e. If there is a one-point increase in the principal's leadership, teacher performance, and the internal quality assurance system together, the increase in the quality of education will increase by 0.301 times ( $0.106 + 0.109 + 0.086$ ).

**Test F**

With the help of Anova table the results of data processing with SPSS program version 20.0 obtained the following data in table 6

**Table 6. ANOVA**

	Model	Sum of Squares	Df	Mean Square	F	Sig.
1	Regression	154,437	3	51,479	3,156	,039 <sup>b</sup>
	Residual	505,735	31	16,314		
	Total	660,171	34			

a. Dependent Variable: Education Quality Improvement

b. Predictors: (Constant), IQA, Teacher performance, Principal's Leadership

Based on the data table 6 obtained F count of 3.156 and sig of 0.039. F table at the level  $\alpha = 0.05$ ,  $df_1 =$  (number of independent variables = 3) and  $df_2$  ( $n-k-1 = 35-3-1 = 31$ ), then the value of  $F_{table} = 2.91$ . This means that  $F_{count} > F_{table}$  ( $3.156 > 2.91$ ) and sig value  $< 0.05$  ( $0.039 < 0.05$ ), it can be concluded that the principal's leadership variables, teacher

performance and internal quality assurance systems jointly influence evident in improving the quality of education.

**The coefficient of determination**

Table 7 below shows how to measure the contribution of the independent variables studied for variations in related variables.

**Table 7. Coefficient of determinatin**

Model	R	R Square	Adjusted R Square	Std. Error of the Estimate	Durbin-Watson
1	,484 <sup>a</sup>	,234	,160	4,039	2,093

a. Predictors: (Constant), IQA,

Teacher performance, Principal's Leadership

b. Dependent Variable: Education Quality Improvement

The value of R is 0.484, while the value of R square is equal to 0.234. The R value has an implication that the principal's leadership variables, teacher performance, and internal

quality assurance systems affect the improvement of the quality of education at SMK Muhammadiyah 1 Bantul by 23.40% and the remaining 76.60% influenced

by other variables outside the model entered in this research.

**Hypothesis Testing at SMK N 1 Pandak  
Multiple Regression Analysis**

To see the influence between the principal's leadership, teacher performance and

the internal quality assurance system of the model school on improving quality in SMK N 1 Pandak, multiple regression analysis was used with the help of the SPSS version 20.0 program, as contained in the following table 8:

**Table 8. Coefficients of multiple regression**

Model	Unstandardized Coefficients		Standardized Coefficients
	B	Std. Error	Beta
(Constant)	3,378	17,898	
1 Principal's Leadership	,150	,156	,173
Teacher performance	,162	,102	,287
IQA	,049	,042	,197

a. Dependent Variable: Education Quality Improvement

From table 8 it can be seen that the value of the multiple linear regression constant is 3.378, with the regression coefficient value of the principal's leadership variable 0,150, the multiple linear regression coefficient value of teacher performance variables is 0.162, and the regression coefficient value of the internal quality assurance system variable is 0.049. Then by referring to the formula of multiple linear regression equation  $\hat{Y} = a + b_1X_1 + b_2X_2 + b_3X_3$ , a multiple linear regression equation can be formed as follows:  $\hat{Y} = 3,378 + 0,150.X_1 + 0,162.X_2 + 0,049.X_3$

The multiple linear regression equation above has the following implications;

- a. If the principal's leadership variables, teacher performance, and internal quality assurance systems are absent ( $X_1, X_2, X_3 = 0$ ), then the improvement in the quality of education is at 3,378

- b. If the addition of one point of the principal's leadership variables is made it will improve the quality of education by 0.150 times.
- c. If the addition of one point of teacher performance variables will improve the quality of education by 0.162 times.
- d. If the addition of one point variable internal quality assurance system is done, it will improve the quality of education by 0.049 times.
- e. If there is a one-point increase in the principal's leadership, teacher performance, and the internal quality assurance system together, the improvement in the quality of education will increase by 0.361 times (0.150 + 0.162 + 0.049).

**Test F**

Test together to see the level of significance of the three independent variables on the dependent variable. Test results together can be seen in the following table 9

**Table 9. ANOVA**

Model	Sum of Squares	Df	Mean Square	F	Sig.
1 Regression	174,964	3	58,321	3,726	,021 <sup>b</sup>
Residual	485,207	31	15,652		
Total	660,171	34			

- a. Dependent Variable: Education Quality Improvement
- b. Predictors: (Constant), IQA, Principal's Leadership, Teacher performance

Data table 9 shows that Fcount is 3,762 and sig 0,021. Ftable at level  $\alpha = 0.05$ ,  $df_1 =$  (number of independent variables = 3) and  $df_2$  ( $n-k-1 = 35-3-1 = 31$ ), then the value of Ftable = 2.91. This means that  $F_{count} > F_{table}$  ( $3.726 > 2.91$ ) and  $sig < 0.05$  ( $0.021 < 0.05$ ), it can be concluded that the principal's leadership variables, teacher performance and internal quality assurance systems jointly influence evident in improving the quality of education.

**The coefficient of determination**

The coefficient of determination test is used to measure the accuracy of the analysis model made the value of the coefficient of determination is a tool to measure the amount of the contribution of the independent variables studied for variations in related variables. The results of the coefficient of determination for each variable are as follows;

**Table 10. Model Summary**

Model	R	R Square	Adjusted R Square	Std. Error of the Estimate	Durbin Watson
1	,515 <sup>a</sup>	,265	,194	3,956	2,144

- a. Predictors: (Constant), IQA, Principal's Leadership, teacher performance
- b. Dependent Variable: Education Quality Improvement

The Model Summary in table 10 shows that the value of R is 0.515, while the value of  $R^2$  is equal to 0.265.. This value has implications that the principal's leadership variables, teacher performance, and internal quality assurance systems affect the improvement of the quality of education in SMK Muhammadiyah 1 Bambanglipuro by

26.50% and the remaining 74.50% is influenced by other variables outside the model included in this research.

The results of the analysis of the average value of report cards using the t-test To find out the improvement in the quality of each school, a test with the results can be seen as shown in the table 11 below.

**Table 11. Independent Samples Test**

		Levene's Test for Equality of Variances		t-test for Equality of Means						
		F	Sig.	t	Df	Sig.(2-tailed)	Mean Difference	Std. Error Difference	95% Confidence Interval of the Difference	
								Lower	Upper	
Average Score	Equal variances assumed	1,804	,188	5,548	36	,000	1,89474	,34154	1,20206	2,58742
	Equal variances not assumed			5,54829	9,911	,000	1,89474	,34154	1,19713	2,59235

Based on the results of the t-test analysis sig. (2-tailed) of 0,000. then the value of sig. 2-tailed  $0,000 < 0.05$ , so it can be concluded that there is a significant difference between improving quality at SMK Muhammadiyah 1 Bambanglipuro and improving quality at SMK N 1 Pandak.

**DISCUSSION**

The school leadership variable (X1) on improving the quality of education (Y) in SMK Muhammadiyah 1 Bambanglipuro has a positive and significant effect. That means the greater the role of the principal in implementing the functions and roles of the principal, the higher the quality of education in SMK Muhammadiyah 1 Bambanglipuro. From the



research findings, the leadership of the school principals obtained from respondents is included in the good category. meanwhile, the influence of the principal's leadership (X1) on improving the quality of education (Y) of SMK N 1 Pandak has a positive and significant influence. That means the greater the role of the principal in implementing the functions and roles of the principal, the higher the quality of education improvement at SMK Muhammadiyah 1 Bambanglipuro (Tang, K.N., Prasertcharoensuk, T., 2017). From the findings of the study, the principal's leadership obtained from respondents is included in either category.

Teacher performance variable (X2) with an increase in the quality of education in SMK Muhammadiyah 1 Bambanglipuro has a positive and significant effect. This means that the better the teacher's performance will also improve the quality of education. Meanwhile, the influence between teacher performance (X2) and improving the quality of education in SMK N 1 Pandak has a positive and significant effect. This means that the better the teacher's performance will also improve the quality of education.

The internal quality assurance system (X3) variable with an increase in the quality of education in SMK Muhammadiyah 1 Bambanglipuro has a positive and significant effect. This means that the more consistent the school is in implementing quality assurance, it will also improve the quality of education. Meanwhile, the influence between the internal quality assurance system (X3) with the improvement of the quality of education in SMK N 1 Pandak has a positive and significant effect. This means that the more consistent the school is in implementing quality assurance it will also improve the quality of education (Simkin, A., Mozhaeva, T., & Proskurin, A., 2019; Mukhopadhyay, M., 2020; Kim, J., 2018).

Headmaster leadership variables, teacher performance, and the internal school

quality assurance system model jointly have a significant effect on improving the quality of education, it is evidenced from the results of the F-test that F-count 3.156 is greater than F-table 2.87 at the significance level of 0.039. means that the three independent variables of the teacher performance, principal's leadership, and the quality assurance system together can be used in predicting an increase in the quality improvement variable at SMK Muhammadiyah 1 Bambanglipuro. Meanwhile, the influence between the teacher performance, principal's leadership, and the internal quality assurance system together significantly influences the improvement of the quality of education with a significance level of 0.021 meaning this means that the three independent variables of the principal's leadership, teacher performance, and the quality assurance system as a whole together can be used in predicting the increase in the variable quality improvement in SMK N 1 Pandak

Based on the results of different tests between SMK Muhammadiyah 1 Bambanglipuro and SMK N 1 Pandak increased education quality from the output of graduates. Different test between the average value of class XI report cards at Muhammadiyah 1 Bambanglipuro Vocational School with the average value of class XI report cards at SMK N 1 Pandak was obtained as a sig. (2tailed) of 0,000. because of the value of sig. 2tailed 0,000 <0.05, it was concluded that there was a significant difference between the average grade of report cards for class XI Muhammadiyah 1 Bambanglipuro Vocational School and the average value of class XI report cards for SMK N 1 Pandak. This means that with different principals' leadership, different teacher performance, and different internal quality assurance practices, the results of graduates when viewed from the acquisition of academic grades (average report card grades) are also different. Based on the assessment guidelines for student learning outcomes if the

scores obtained from 80-84 can be categorized as "good". Then it can be concluded that student achievement when viewed from the average grade of report cards for class XI students of SMK Muhammadiyah 1 Bambanglipuro of 80.0 can be categorized as "good". Likewise, the average grade of report cards for class XI at SMK N 1 Pandak of 81.9 can be categorized as "good".

The implication of the results of this study shows that improving the quality of education is a very important thing that needs to be improved (Piawa, C.Y., Heeb, T.F., Ismail, N.R., Ying, L.H., 2014). Improving the quality of education in vocational high schools is influenced by several factors, namely academic factors and managerial factors. Academic factors related to the effectiveness of the implementation of school learning, the capacity and qualifications of educators in the learning process, supporting facilities for the implementation of the learning process, including teacher performance as indicated by the results of teacher supervision in schools. Managerial factors related to the ability of schools in this case the principal in carrying out their functions and roles in managing education in schools. The principal's leadership pattern becomes a very influential factor in improving the quality of education. School principals must be able to mobilize all teachers together to advance or improve school quality. Each work unit in a school organization must be able to empower and come up with ideas/ideas in the form of quality improvement concepts that are realized in the form of activities.

Principals must be able to provide motivation to teachers to always improve performance and carry out work as a mandate that must be carried out as well as possible for the achievement of school goals. Between teachers, harmonious relationships must be formed as capital in developing schools. The principal must be able to build a school culture that is quality culture. The quality culture is a

whip for every teacher in carrying out the task that everything must be carried out with a good process and produce superior quality, especially improving the quality of education in schools.

In school organizations to achieve common goals, togetherness needs to be continued. For this reason, there must be a leadership pattern that can protect, provide a sense of comfort and security, and is conducive to carrying out work in schools. So that it can change the attitudes, actions, and behavior of school organization members (principals, teachers, and employees) into a positive attitude. This attitude will foster teacher morale in the learning process at school so that teacher performance is maximized. If the performance of the teacher is maximum, then improving the quality of education in schools will be easily achieved (Jubran, 2015).

Quality assurance of school education is needed to ensure that the learning process carried out in schools has been in accordance with the standard reference and has been carried out with relevant programs (Simkin, A., Mozhaeva, T., & Proskurin, A., 2019; Mukhopadhyay, M., 2020; Kim, J., 2018).

Quality assurance is a systemic cycle as a controlling container for program implementation so that implementation is organized and can be accounted for. The pattern of quality assurance is always endeavored to always prioritize quality improvement and continuous improvement, which is always prioritizing quality improvement (Maris, Komariah, Abubakar, 2016). So with this pattern, if applied in education, the improvement of the quality of education will be realized.

Principals must be able to explore the potential of human resources at the school, to be maximally empowered according to their field of expertise to implement programs to improve the quality of education in schools (Militarua, M., Ungreanua, G., Chenic, AS,

2013). The headmaster should implement leadership that can protect and organize the school effectively and efficiently.

Teacher performance variables are the most influential variables related to improving the quality of education, therefore teacher performance in learning in schools needs to be continuously improved. School principals and teachers must work together to improve the quality of education by being controlled by a credible school quality assurance system.

## CONCLUSIONS

The study shows that, first, school principal leadership, teacher performance, and internal quality assurance systems have a significant effect on improving the education quality of SMK Muhammadiyah 1 Bambanglipuro, where the contribution is given is 23.40% and the regression equation obtained is  $\hat{Y} = 3,138 + 0,106X_1 + 0,109X_2 + 0,086X_3$ , while the principal's leadership, teacher performance, and internal quality assurance system together have a significant effect on improving the education quality at SMK N 1 Pandak, where the contribution is 26.50% and the regression equation obtained is  $\hat{Y} = 3,378 + 0,150X_1 + 0,162X_2 + 0,049X_3$ . Second, there is a difference in quality improvement, which means that there are significant differences in quality between SMK Muhammadiyah 1 Bambanglipuro and SMKN 1 Pandak.

## REFERENCES

Ahmad, S., & Batool, A. (2020). Identification of Quality Indicators in Teacher Education Program. Angeli, C., Valanides, N., & Bonk, C. J. (2003). Communication in a web-based conferencing system: the quality of computer-mediated interaction. *British Journal of Educational Technology*, 34(1), 31–43.

- Balta, N., Mason, A. J., & Singh, C. (2016). Surveying Turkish high school and university students' attitudes and approaches to physics problem solving. *Physical Review Physics Education Research*, 12(1), 010129. <http://doi.org/10.1103/PhysRevPhysEducRes.12.010129>
- Boies, K., & Fiset, J. (2019). I Do as I Think: Exploring the Alignment of Principal Cognitions and Behaviors and Its Effects on Teacher Outcomes. *Educational Administration Quarterly*, 55(2), 225-252.
- Boies, K., & Fiset, J. (2019). I Do as I Think: Exploring the Alignment of Principal Cognitions and Behaviors and Its Effects on Teacher Outcomes. *Educational Administration Quarterly*, 55(2), 225-252.
- Clifton, J., & Jordan, K. (2019). Who Is the Hybrid Teacher Educator? Understanding Professional Identity in School–University Partnership. In *Professionalism and Teacher Education* (pp. 71-90). Springer, Singapore.
- Davis, B. W., & Bowers, A. J. (2019). Examining the career pathways of educators with superintendent certification. *Educational Administration Quarterly*, 55(1), 3-41.
- DU, J. C. (2019). Cultural sustainability with arts management, minority cultural education and. *Ann Arbor*, 1001, 48106-1346.
- Eren, A., & Çetin, G. (2019). Pre-service teachers' beliefs about the teaching profession, curriculum orientations, and personal responsibility. *Curriculum Perspectives*, 39 (1), 19-32.

- Fitriyah, I., Santosa, A.B., (2020). Principal's Leadership in Facing the Era of the Industrial Revolution 4.0 to Improve School Quality. *Journal of Management, Leadership, and Educational Supervision*. 5 (1), 65-70.  
<http://dx.doi.org/10.31851/jmksp.v5i1.3538>
- Garira, E., Howie, S., & Plomp, T. (2019). An analysis of quality of education and its evaluation: A case of Zimbabwean primary schools. *South African Journal of Education*, 39(2).
- Hafidhah, R. N., & Martono, S. (2019). The Effect of Perceived Organizational Support, Job Stress, and Organizational Culture on Job Performance. *Management Analysis Journal*, 8(2), 177-187.
- Hardwick-Franco, K. G. (2019). Educational leadership is different in the country; What support does the rural school principal need?. *International Journal of Leadership in Education*, 22(3), 301-314.
- Heyder, A., Weidinger, A. F., Cimpian, A., & Steinmayr, R. (2020). Teachers' belief that math requires innate ability predicts lower intrinsic motivation among low-achieving students. *Learning and Instruction*, 65, 101220.
- Ishtiaq, M. (2019). Book Review Creswell, JW (2014). *Research Design: Qualitative, Quantitative and Mixed Methods Approaches*. Thousand Oaks, CA: Sage. *English Language Teaching*, 12(5), 40.
- Istiningsih, E., Santosa, A.B., (2020). Enhancing Pedagogical and Professional Competence of Vocational School Teachers Through Principal Supervision. *International Journal of Scientific & Technology Research*. 9 (01), 1501-1507.  
<http://www.ijstr.org/final-print/jan2020/Enhancing-Pedagogical-And-Professional-Competence-Of-Vocational-School-Teachers-Through-Principal-Supervision.pdf>
- Jubran, A.M., (2015). Educational Leadership: A new Trend that Society Needs. *Procedia-Social and Behavioral Sciences*. Elsevier, 210: 28 - 34
- Kaufman, B. E. (2019). *Managing the human factor: The early years of human resource management in American industry*. Cornell University Press.
- Keller-Schneider, M., Zhong, H. F., & Yeung, A. S. (2020). Competence and challenge in professional development: teacher perceptions at different stages of career. *Journal of Education for Teaching*, 1-19.
- Kim, J. (2018). School accountability and standard-based education reform: The recall of social efficiency movement and scientific management. *International Journal of Educational Development*, 60, 80-87.
- Knollmann, M., Reissner, V., & Hebebrand, J. (2019). Towards a comprehensive assessment of school absenteeism: development and initial validation of the inventory of school attendance problems. *European child & adolescent psychiatry*, 28(3), 399-414.
- Latif, K. F., Latif, I., Farooq Sahibzada, U., & Ullah, M. (2019). In search of quality: measuring higher education service quality (HiEduQual). *Total Quality Management & Business Excellence*, 30(7-8), 768-791.
- Lunenburg, C.F., & Ornstein, C. A. (2010). *Educational Administration: Concept and Practices*. Wadsworth Publishing 6 edition.

- Maris, I.S., Komariah, A., Abubakar, (2016). Principal Transformational Leadership, Teacher Performance, and School Quality. *Journal of Educational Administration*. UPI: Vol.XXIII, 2: 173 - 188
- Marquis, B. L., & Huston, C. J. (2009). *Leadership roles and management functions in nursing: Theory and application*. Lippincott Williams & Wilkins.
- McCruden, M. T., Marchand, G., & Schutz, P. (2019). Mixed methods in educational psychology inquiry.
- Merriam, S. B., & Baumgartner, L. M. (2020). *Learning in adulthood: A comprehensive guide*. John Wiley & Sons.
- Mikkonen, K., Tuomikoski, A. M., Sjögren, T., Koivula, M., Koskimäki, M., Lähteenmäki, M. L., ... & Koskinen, C. (2020). Development and testing of an instrument (HeSoEduCo) for health and social care educators' competence in professional education. *Nurse education today*, 84, 104239.
- Militaru, M., Ungureanu, G., Chenic, A.S., (2013). The prospects of implementing the principles of Total Quality Management (TQM) in education. *Procedia-Social and Behavioral Sciences*. Elsevier, 93: 1138 - 1141
- Ministry of Education and Culture. (2017). *Guidelines for Implementing Educational Quality Assurance by Education Units*
- Mitchell, D., & Sutherland, D. (2020). *What really works in special and inclusive education: Using evidence-based teaching strategies*. Routledge.
- Mixon, C. S., Owens, J. S., Hustus, C., Serrano, V. J., & Holdaway, A. S. (2019). Evaluating the impact of online professional development on teachers' use of a targeted behavioral classroom intervention. *School Mental Health*, 11(1), 115-128.
- Mosha, H. (2018). The state and quality of education in Tanzania: A reflection. *Papers in Education and Development*, (31).
- Moscoviz, L., & Bélanger, J. (2019). Quality indicators in Public and Private Pre-Schools: Evidence from Cote d'Ivoire.
- Mukhopadhyay, M. (2020). *Total quality management in education*. SAGE Publications Pvt. Limited.
- Piawa, C.Y., Heeb, T.F., Ismail, N.R., Ying, L.H., (2014). Factors of leadership skills of secondary school principals, Factors of leadership skills of secondary school principals. *Procedia-Social and Behavioral Sciences*. Elsevier, 116: 5125 – 5129
- Prasertcharoensuk, T., Tang, K.N., (2017). The effect of strategic leadership factors of administrators on school effectiveness under the Office of Maha Sarakham Primary Educational Service Area 3. *Kasetsart Journal of Social Sciences*. 38: 316 - 323
- Quynh, N. L. T., & Huu, C. N. (2020). Needs for Consultancy of Vietnam high school students. *Archives of Business Research*, 8(3), 15-22.
- Republic of Indonesia Law No.20 of 2003 on National Education System.
- Republic of Indonesia Law No.14 of 2005 on Teachers and Lecturers
- Scarneo, S. E., DiStefano, L. J., Stearns, R. L., Register-Mihalik, J. K., Denegar, C. R.,

- & Casa, D. J. (2019). Emergency Action Planning in Secondary School Athletics: A Comprehensive Evaluation of Current Adoption of Best Practice Standards. *Journal of athletic training*, 54(1), 99-105.
- Sihotang, H., & Nadeak, B. (2017). Leadership Based on the Internal Quality Assurance System in the Christian University of Indonesia. In *Ist Yogyakarta International Conference on Educational Management/Administration and Pedagogy (YICEMAP 2017)*. Atlantis Press.
- Sihotang, H. (2020). Improvement of Teacher Professionalism in the Industrial Revolution Era 4.0 With Character Building and Higher Order Thinking Skills (Case Study of Schools in South Nias District). *Journal of educational dynamics*. 13(1), 68-78.
- Simkin, A., Mozhaeva, T., & Proskurin, A. (2019). The Quality Management System of Additional Professional Education in Higher Educational Institution on the Basis of a Standard Quality System. In *MATEC Web of Conferences* (Vol. 297, p. 06010). EDP Sciences.
- Tuytens, M., Moolenaar, N., Daly, A., & Devos, G. (2019). Teachers' informal feedback seeking towards the school leadership team. A social network analysis in secondary schools. *Research Papers in Education*, 34(4), 405-424.
- Wahjosumidjo, (2013). *Principal's leadership, theoretical review and problems* Jakarta Raja Grafindo Persada
- Wu, R., Ma, Q., Xiong, J., Xu, Z., & Li, Y. (2020). Leadership roles and group climate in isolation: A case study of 4-subject 180-day mission. *Acta Astronautica*, 166, 554-559.
- Yang, G., Badri, M., Al Rashedi, A., & Almazroui, K. (2019). Predicting teacher commitment as a multi-foci construct in a multi-cultural context: the effects of individual, school, and district level factors. *Teachers and Teaching*, 25(3), 301-319.
- Yoda, T. C. (2019). Analysis Effect of Exchange Rates and Interest Rates of Bank Indonesia On Share Price. *Jurnal Menara Ekonomi: Penelitian Dan Kajian Ilmiah Bidang Ekonomi*, 5(1).