



# Turnitin Perpustakaan UKI

## The mediating role of social influence in ChatGPT-assisted English learning performance A sociocultural analysis in Indon...

-  Turnitin Dosen 1
-  Turnitin Dosen - Mei
-  Universitas Kristen Indonesia

---

### Document Details

**Submission ID**

trn:oid::1:3558241275

**Submission Date**

May 4, 2026, 8:02 AM GMT+7

**Download Date**

May 29, 2026, 3:22 PM GMT+7

**File Name**

ance\_A\_sociocultural\_analysis\_in\_Indonesian\_higher\_education.pdf

**File Size**

961.7 KB

26 Pages

14,784 Words

85,248 Characters

# 15% Overall Similarity

The combined total of all matches, including overlapping sources, for each database.





## Filtered from the Report

- ▶ Bibliography
- ▶ Cited Text



## Exclusions

- ▶ 10 Excluded Sources
- ▶ 4 Excluded Matches

## Match Groups

-  **188 Not Cited or Quoted** 15%  
Matches with neither in-text citation nor quotation marks
-  **0 Missing Quotations** 0%  
Matches that are still very similar to source material
-  **1 Missing Citation** 1%  
Matches that have quotation marks, but no in-text citation
-  **0 Cited and Quoted** 0%  
Matches with in-text citation present, but no quotation marks

## Top Sources

- 12%  Internet sources
- 12%  Publications
- 4%  Submitted works (Student Papers)

## Integrity Flags

### 0 Integrity Flags for Review

No suspicious text manipulations found.

Our system's algorithms look deeply at a document for any inconsistencies that would set it apart from a normal submission. If we notice something strange, we flag it for you to review.

A Flag is not necessarily an indicator of a problem. However, we'd recommend you focus your attention there for further review.

### Match Groups

- **188** Not Cited or Quoted 15%  
Matches with neither in-text citation nor quotation marks
- **0** Missing Quotations 0%  
Matches that are still very similar to source material
- **1** Missing Citation 1%  
Matches that have quotation marks, but no in-text citation
- **0** Cited and Quoted 0%  
Matches with in-text citation present, but no quotation marks

### Top Sources

- 12% Internet sources
- 12% Publications
- 4% Submitted works (Student Papers)

### Top Sources

The sources with the highest number of matches within the submission. Overlapping sources will not be displayed.

1	Publication	Erni Murniarti, Goklas Siahaan. "The synergy between artificial intelligence and e...	<1%
2	Internet	www.mdpi.com	<1%
3	Publication	Mohamad Rizan, Efriyani Sumastuti, Heri Prabowo, Agung Kresnamurti et al. "Th...	<1%
4	Internet	repository.untagsmg.ac.id	<1%
5	Internet	www.academypublication.com	<1%
6	Internet	ejournal.up45.ac.id	<1%
7	Student papers	University of Anbar	<1%
8	Publication	Subhan Zein, Fuad Abdul Hamied. "The Routledge International Handbook of Eng...	<1%
9	Internet	fileserver-az.core.ac.uk	<1%
10	Publication	"Corporate Practices: Policies, Methodologies, and Insights in Organizational Ma...	<1%

11	Internet	core.ac.uk	<1%
12	Student papers	Universitas Negeri Jakarta	<1%
13	Internet	bura.brunel.ac.uk	<1%
14	Internet	onlineacademicpress.com	<1%
15	Internet	journal.walisongo.ac.id	<1%
16	Publication	Akatwijuka, Habassa Ivan. "Financial Management Practices and Performance of ...	<1%
17	Student papers	Manchester Metropolitan University	<1%
18	Internet	research.ou.nl	<1%
19	Internet	openpublichealthjournal.com	<1%
20	Internet	www.al-kindipublisher.com	<1%
21	Internet	www.preprints.org	<1%
22	Publication	Bolajoko Elizabeth Otegbayo, Mahmoud Danaee, Noralina Omar, Nasrin Aghamo...	<1%
23	Internet	auojs.au.edu	<1%
24	Internet	pmc.ncbi.nlm.nih.gov	<1%

25	Internet	admin.calitatea.ro	<1%
26	Student papers	Central Library	<1%
27	Internet	api.research-repository.uwa.edu.au	<1%
28	Internet	repository.lib.ncsu.edu	<1%
29	Publication	Moreno Bonilla, Carlos Andrés. "Examining the Relationship Between Artificial Int..."	<1%
30	Internet	etd.uwc.ac.za	<1%
31	Internet	www.science.gov	<1%
32	Internet	www.tandfonline.com	<1%
33	Student papers	City University Malaysia	<1%
34	Publication	Galiya Utebayeva. "Learning English in the era of artificial intelligence: Graduate ..."	<1%
35	Internet	baixardoc.com	<1%
36	Internet	repository.uhamka.ac.id	<1%
37	Internet	tanmeah.com	<1%
38	Publication	Ramalepe, Prince. "The Perceptions of Fet Language Teachers in Using Chatgpt to..."	<1%

39	Student papers	Language Institute : Thammasat University	<1%
40	Publication	Xiaoshu Xu. "AI and Security in China's Higher Education - Challenges and Respon...	<1%
41	Internet	jurnal.arkainstitute.co.id	<1%
42	Internet	www-emerald-com-443.webvpn.sxu.edu.cn	<1%
43	Internet	files.eric.ed.gov	<1%
44	Internet	journalijsra.com	<1%
45	Publication	Andrew K.F. Cheung, Dechao Li, Kanglong Liu, Riccardo Moratto. "Technology and...	<1%
46	Publication	Khoirul Fuad, Septian Satria Ady Pamungkas, Farah Aida Ahmad Nadzri, Sharina T...	<1%
47	Student papers	University of Lancaster-Main Account	<1%
48	Internet	ejournal.stainkepri.ac.id	<1%
49	Internet	mail.msocialsciences.com	<1%
50	Internet	scholar.sun.ac.za	<1%
51	Internet	www.eu-jer.com	<1%
52	Internet	www.scielo.org.mx	<1%

53	Publication	Krishna Koppa, Manita D. Shah, Srimantoorao S. Appadoo. "Empowering Inclusive..."	<1%
54	Publication	Mohamed Mekheimer. "A diagnostic assessment of translation competence: ling..."	<1%
55	Publication	Stephen J. Farena, Salvatore G. Garofalo, Daniel Ness. "International Handbook ..."	<1%
56	Internet	managementworld.online	<1%
57	Internet	researchspace.auckland.ac.nz	<1%
58	Internet	www.researchsquare.com	<1%
59	Internet	www.sportifbakis.com	<1%
60	Publication	Aseel Ajlouni, Amal Ibrahim, Manal Hendawi. "Predicting Preservice Teachers' Int..."	<1%
61	Publication	Boğaz, Nermin. "Examining the Perceptions of EFL Instructors on AI Integration i..."	<1%
62	Publication	Koko Hermanto, Nora Dery Sofya, Harizahayu. "Analysis of differences in word-of..."	<1%
63	Publication	Ling Wei. "Artificial intelligence in language instruction: impact on English learni..."	<1%
64	Publication	Nguyen Huu Hoang. "ChatGPT-assisted language learning: Effects on Vietnamese..."	<1%
65	Publication	Sariana, Mahfudnurnajamuddin, Mursalim Laekkeng, Lukman Chalid. "The Influe..."	<1%
66	Internet	revistia.com	<1%

67	Internet	www.erudit.org	<1%
68	Publication	Gunn, Tiffany S.   Howell, Gabrielle. "Educational Experiences and a Sense of Belon...	<1%
69	Student papers	HOLY TRINITY COLLEGE	<1%
70	Publication	Naniana N. Benu, Mauli Denil, Lery Prasetyo. "Representation of Political Identity...	<1%
71	Publication	Nyakondo, Charles D.. "Refugee Learners' Readiness for Emerging Mobile Learnin...	<1%
72	Publication	Ramesh Chandra Das. "Societal Implications of Fiscal and Monetary Policies - Doe...	<1%
73	Publication	Said S. Al-Gahtani, Malcolm King. "Attitudes, satisfaction and usage: Factors contr...	<1%
74	Internet	au-east.erc.monash.edu.au	<1%
75	Internet	d1wqtxts1xzle7.cloudfront.net	<1%
76	Internet	fslmjournals.taylors.edu.my	<1%
77	Internet	iceb.johogo.com	<1%
78	Internet	openjournal.unpam.ac.id	<1%
79	Internet	proceedings.uinsaizu.ac.id	<1%
80	Internet	www.aasmr.org	<1%

81	Internet	www.coursehero.com	<1%
82	Internet	www.physiciansweekly.com	<1%
83	Publication	Ida Fatimawati Adi Badiozaman, Augustus Raymond Segar. "Pedagogical Innovat...	<1%
84	Publication	Maila D.H. Rahiem. "Towards Resilient Societies: The Synergy of Religion, Educati...	<1%
85	Publication	Mutiga, Anne N.. "AI Integration in Higher Education: A Content Analysis on AI So...	<1%
86	Publication	Ngope, Margaret Mosima. "Constructing a Career Guidance Framework to Enhan...	<1%
87	Publication	Qian Xu. "Action Research Plan: The impact of the use of Artificial Intelligence in ...	<1%
88	Publication	Yu, Pin. "Public Attitudes Toward the Victim-Offender Reconciliation System-An E...	<1%
89	Internet	artseduca.com	<1%
90	Internet	bucks.collections.crest.ac.uk	<1%
91	Internet	consortiacademia.org	<1%
92	Internet	ejournal.risetanakbangsa.id	<1%
93	Internet	ejournal.ung.ac.id	<1%
94	Internet	eprints.utar.edu.my	<1%

95	Internet	i-jte.phamho.com	<1%
96	Internet	journal.presscience.org	<1%
97	Internet	journal.unhas.ac.id	<1%
98	Internet	marketing.expertjournals.com	<1%
99	Internet	multilinguaeducation.openjournals.ge	<1%
100	Internet	ojs.transpublika.com	<1%
101	Internet	publishup.uni-potsdam.de	<1%
102	Internet	real-j.mtak.hu	<1%
103	Internet	researchsystem.canberra.edu.au	<1%
104	Internet	resistances.religacion.com	<1%
105	Internet	rsujournals.rsu.ac.th	<1%
106	Internet	tesol.hufliit.edu.vn	<1%
107	Internet	tljbm.org	<1%
108	Internet	tpmap.org	<1%

109	Internet	www.assajournal.com	<1%
110	Internet	www.regent.edu	<1%
111	Internet	www.researchgate.net	<1%
112	Publication	Hodson, Phyllis J.. "Teaching in the Age of Generative Artificial Intelligence: A Qua...	<1%
113	Publication	Interactive Technology and Smart Education, Volume 12, Issue 3 (2015)	<1%
114	Publication	Joseph Rene Corbeil, Maria Elena Corbeil. "Teaching and Learning in the Age of ...	<1%
115	Publication	Simona Christina Henderika Litaay, Feky M. L. Manuputty, Afdhal Afdhal, Nathali...	<1%
116	Publication	Xiaofei Zhen. "Application of artificial intelligence in English learning: The interac...	<1%
117	Internet	ijels.com	<1%
118	Publication	Bester, Petri. "A Consumer-Based, Consumer-Perceived Brand Equity Model for R...	<1%
119	Publication	Muharrem Kılıç, Sezer Bozkuş Kahyaoğlu. "Digitalization and Women's Rights", C...	<1%
120	Publication	Rod Case, Leping Liu, Joseph Mintz. "Integrating Artificial Intelligence Technology...	<1%
121	Internet	cdn.juris.id	<1%
122	Internet	journal.ipb.ac.id	<1%

**International Journal of Education and Practice**

2026 Vol. 14, No. 1, pp. 554-579  
 ISSN(e): 2310-3868  
 ISSN(p): 2311-6897  
 DOI: 10.18488/61.v14i1.4770  
 © 2026 Conscientia Beam. All Rights Reserved.



**The mediating role of social influence in ChatGPT-assisted English learning performance: A sociocultural analysis in Indonesian higher education**

**Masda Surti Simatupang<sup>1+</sup>**

**Gunawan Tambunsaribu<sup>2</sup>**

**Ramot Peter<sup>3</sup>**

**Ronny Gunawan<sup>4</sup>**

**Erni Murniarti<sup>5</sup>**

<sup>1,2,4,5</sup> Universitas Kristen Indonesia, Jakarta, Indonesia.

<sup>1</sup>Email: [mssimatupang@uki.ac.id](mailto:mssimatupang@uki.ac.id)

<sup>2</sup>Email: [gunawan.tambunsaribu@uki.ac.id](mailto:gunawan.tambunsaribu@uki.ac.id)

<sup>3</sup>Email: [ronny.gunawan@uki.ac.id](mailto:ronny.gunawan@uki.ac.id)

<sup>4</sup>Email: [emurniarti@uki.ac.id](mailto:emurniarti@uki.ac.id)

<sup>5</sup> Universitas Bina Nusantara, Jakarta, Indonesia.

<sup>5</sup>Email: [ramot.peter@binus.ac.id](mailto:ramot.peter@binus.ac.id)



(+ Corresponding author)

**ABSTRACT**

This study investigates the mediating role of social interaction in the relationship between sociocultural factors and English language learning performance using ChatGPT as an AI-integrated learning tool in Indonesian higher education. As the integration of generative AI like ChatGPT becomes increasingly relevant to global education, this research explores how sociocultural elements influence students' performance through the lens of social influence. Employing a quantitative methodology, data were gathered from 220 undergraduate students across multiple universities in Jakarta through a structured online survey. Structural Equation Modeling (SEM) using LISREL 8.80 was applied to examine the relationships among constructs: sociocultural influences, social influence, and learning performance. Findings reveal a significant positive effect of ChatGPT-assisted learning on students' English proficiency, mediated by motivation ( $\beta = 0.41, p < 0.001$ ). Social influence was found to significantly mediate the relationship between sociocultural factors and performance (indirect effect = 0.29,  $R^2 = 0.38$ ), underscoring the importance of peer dynamics in technology-driven education. Theoretically, the study extends Vygotsky's sociocultural learning framework and integrates the Technology Acceptance Model (TAM) and Cultural Intelligence Theory (CIT), emphasizing that cultural background and social interaction are key to the adoption and success of AI in education. Practically, the findings suggest educators and policymakers must consider social and cultural dimensions when designing curricula that integrate AI tools like ChatGPT. The research advocates for inclusive, socially engaging, and culturally sensitive digital learning environments to optimize AI adoption and enhance English language learning outcomes in multilingual contexts.

**Article History**

Received: 25 June 2025  
 Revised: 10 December 2025  
 Accepted: 23 January 2026  
 Published: 12 February 2026

**Keywords**

ChatGPT-assisted learning  
 English language proficiency  
 Higher education  
 Social influence  
 Sociocultural factors  
 Structural equation modeling.

**Contribution/Originality:** This study contributes to the existing literature by examining AI-assisted learning technology in English reading classes among Jakarta universities. It is one of the few studies that investigate purposive sampling of ELP students, documenting how prior knowledge supports technology-enhanced learning experiences.

**1. INTRODUCTION**

In the era of globalization, where the world is becoming more borderless, Indonesian universities are in a dire need of catching up with the new trends of social and cultural practices, which in turn may impact student learning. An example of one such latest breakthrough that overcomes the aforementioned hurdles is integrating AI-powered

24

35

64

55

101

103

85

49

62

tools such as ChatGPT in English language teaching. This research aims to investigate social and cultural factors and the effectiveness of English learning assisted by ChatGPT on social influence in Indonesian higher education.

The deployment of AI technologies in education represents a new paradigm of teaching models, with increasingly pervasive technology integrated into learning environments. Earlier work has confirmed that systems like ChatGPT have the potential to enhance learner engagement and academic success by offering personalized and ubiquitous support for language in the form of scaffolding (Abd Rahim, Abd Rahim, Razawi, & Mohamed, 2023). The paper explores how Indonesian students' diverse sociocultural settings influence perceptions and acceptance of ChatGPT-mediated English learning, which has been overlooked in the field of educational technology in Southeast Asia. User behavior may be influenced by cultural factors, including technology use and classroom interaction (Fu et al., 2004; Hajro, 2014).

Evidence suggests that AI-driven tools hold the promise of improving adult learners' overall learning experience, especially if these tools address the motivational and social needs of learners (Ahn, 2024). The study indicates that social interaction, especially peer and instructor relationships, plays a significant role in sustaining learners' interaction (Ali, Shamsan, Hezam, & Mohammed, 2023). Social influence, a reflection of the collectivist dimension, in an Indonesian setting, was also discovered to mediate technology use for learning (Prasetya & Syarif, 2023). Thus, it is critical to understand the impact of social and cultural conditions on the utilization of technology as a pedagogical tool.

The aim of this research is to provide empirical evidence regarding culture and social variables, social influence, and English proficiency in AI-based learning environments. The purpose is to give an overview of curriculum and instructional design that is contextually sensitive within the Indonesian higher education system. The study thereby contributes to the broader debate on the digital transformation of education and policy implications of using generative AI tools in various linguistic and cultural learning contexts.

What makes this study particularly special is that it will bridge the gap between sociocultural theory and technology acceptance models in order to examine ChatGPT-facilitated English learning in Southeast Asia. Unlike those prior studies, which are mostly concerned with technological adoption, the present study emphasizes the social and cultural factors mediating technology-facilitated learning, providing a culturally situated perspective on AI in education integration.

## 2. LITERATURE REVIEW

### 2.1. Theoretical Framework

The article establishes a theoretical framework for investigating the effects of culture and social support in ChatGPT-aided English learning at the level of Indonesian higher education. The model is based on three major theories, namely: the TAM, CIT, and Vygotsky's Sociocultural Learning Theory.

The basic element of this Technology Acceptance Model as described by Davis (1985) is that users' perceptions of a system's usefulness and ease of use are fundamental to adoption. In an educational setting, this may imply that college students are more willing to incorporate ChatGPT in their learning behaviors if they feel it is accessible and pedagogically useful. Consistent with this viewpoint is the study by Ahmad, Tajul Urus, and Syed Mustapha Nazri (2021) that the easier access to technology, the higher the tendency of adopting digital learning tools. Similarly, Ali et al. (2023) showed that 76% of students using ChatGPT thought that it would make them more motivated to learn English.

Cultural Intelligence Theory Ang et al. (2007) frames the capability of individuals to understand and adjust to various cultural norms, values, and practices something highly applicable given the vast cultural diversity of higher education in Indonesia. As shown in the work of Zhao, Osman, Omar, and Yaakup (2022), students' cultural identity strongly influences their use and interaction with digital environments in their approach to language learning. In

this context, ChatGPT is not only an artifact to support language learning but also a cross-cultural communication tool, which can support cross-cultural awareness and global citizenship.

Vygotsky's Sociocultural Learning Theory also supports that learning is social and context-dependent by nature. One builds knowledge primarily by interacting with others and secondarily within their cultural context. The interactive capabilities of ChatGPT can encourage cooperation, peer discussion, and an active learning environment.

It has been suggested that the mediating variable between sociocultural characteristics and learning outcomes is social influence. Fu et al. (2004) stated that cultural beliefs chart the course for how a person responds to persuasive appeals, including those in education. Consistent with this, Syahid, Basahil, Lestari, Fatma, and Ningrum (2023) 68% of students felt more motivated when encouraged by their peers, lecturers or family members. In the collectivist culture of Indonesia, social support plays a significant role in technology adoption and language learning.

This theoretical perspective has a significant bearing on language education policy and practice in Indonesia. By learning how sociocultural forces and social influence structure students' engagement with AI tools like ChatGPT, institutions can create more effective and culturally responsive curricula. Further studies may go on to explore the generalization of the current model in various institutional contexts, sociocultural contexts, as well as technology-supported contexts, thus contributing to the understanding of the implementation of AI in language learning.

## 2.2. Social and Cultural Influences

Social and cultural variables strongly influence K-12 and higher education students' learning practices and attitudes. According to Venkatesh and Davis (2000), social influence refers to the degree to which individuals feel pressure from peers, family, and instructors to behave socially. Collaborative learning, peer support, and feedback within the classroom can significantly enhance language acquisition.

In Indonesia, academic achievement depends on social support. Abd Rahim et al. (2023) revealed that 65% of students valued family and friend assistance for academic achievement. Ali et al. (2023) found that group-based language learning boosted academic performance and intrinsic motivation. Interactive engagement technologies like ChatGPT boost students' English enthusiasm and confidence (Prasetya & Syarif, 2023).

Cultural influences on pupils' language development are equally significant. Bilingual students in Indonesia utilize English and their local languages, which helps them learn complex languages. Cultural background improves pupils' communication ability and understanding of language intricacies, according to Baresh (2024). According to Maqsood, Zahid, Asghar, Farooqi, and Shahbaz (2024) multicultural students see English learning through culturally conditioned glasses, which reduces motivation and engagement.

Complex learning environments result from social and cultural factors. Students' cultural origins affect peer relationships, involvement, and language learning value. Zhao, Osman, Omar, and Yaakup (2022) found that overseas students in Malaysia struggled to adapt to new social norms, which hurt their classroom participation and academic performance. In contrast, language learners from educational and collaborative cultures prosper (Govindarajan & Christuraj, 2023).

University social climates should prioritize peer cooperation to promote meaningful learning. Ahn (2024) states that collaborative learning settings boost student engagement and perseverance. Teachers may encourage this by including group projects, peer evaluation, and collaborative conversation. ChatGPT and other AI technologies may also aid culturally sensitive education. The interactive language practice and culturally appropriate information in these tools improve students' language and intercultural skills. Juan, Qing, Yunus, and Rafiq (2023) showed that AI-enhanced education boosts language acquisition and communication abilities.

## 2.3. ChatGPT in Language Learning

Artificial Intelligence (AI) has been widely used in educational settings in recent years, particularly in language learning. One of the game-changing products in this category is ChatGPT, which is an OpenAI-developed generative

117 language model. Its features, ranging from personalized learning pathways to real-time feedback and interactive language practice, make it relevant as a tool for English language teaching. In a recent study by Abd Rahim et al. (2023) revealed that 75% of Indonesian university students were more motivated to learn English after using ChatGPT.

In education, ChatGPT serves as a virtual language tutor, helping students get language support anywhere, anytime, regardless of other schedules, which has been especially important during the pandemic. Ali et al. (2023) concluded that students seen ChatGPT had a 30% and more motivation to traditional teaching methods. The model's dialogue architecture encourages active learning and can help in shaping writing and speaking skills. Prasetya and Syarif (2023) talked about how ChatGPT is a strategic complement to formal learning because it is adaptive and pace-controlled by the students. Its real-time feedback is what makes it so invaluable for language learning. Feedback provided in a timely manner facilitates learning retention and assists in the faster development of the learner, as stated by Phuong (2024) for a key advantage over the traditional delayed teacher responses.

40 Yet incorporating ChatGPT into academic language courses also presents pedagogical and ethical quandaries. The most prominent of these is the risk of AI-generated but unattributed plagiarism (Zou, Su, Li, & Fu, 2023). An over-reliance on automated responses may diminish the richness of students' critical thinking and writing skills, leading to less deep cognitive engagement (Sallam, 2023). Furthermore, Kim, Lee, and Cho (2022) caution that overreliance on AI tools may impede creativity and learner autonomy. Issues such as algorithmic bias and disinformation also highlight the importance of ethical oversight in AI-driven learning environments (Jamali, 2023).

5 To mitigate such risks, schools should define clear policies on the responsible use of AI tools in language learning. Syahid et al. (2023) advise to define acceptable contexts for the use of AI in interactive practice and post-lesson review, while discouraging it in assessments or original writing. Furthermore, academic institutions need to establish methods for enforcing academic integrity, a citation literacy program, and also instruction on the ethical use of AI (Spector & Ma, 2019).

That said, the NLP superpower of ChatGPT could enable some interesting benefits for immersive and contextual learning, despite these cautions. Imitation can allow students to practice real-life communication in context. Govindarajan and Christuraj (2023) proved that chatGPT enables more engaging with enhanced vocabulary, fluency, pronunciation, and grammatical accuracy. Student reactions to AI-facilitated learning environments have generally been very positive, and have often featured increased engagement, confidence and learner independence. For example, Pratama and Hastuti (2024) in their study, it was discovered that students encouraged the use of ChatGPT for writing activities to improve the quality of their work and to become more engaged in their classroom activities. These results underscore the importance of AI-based platforms in addressing motivational shortfalls and supporting traditional pedagogical models.

#### 2.4. Social Influence (SI)

94 Social influence: The factors involving the presence, behavior, or expectations of other people are among the factors that influence the personal behavior of a patient within the social environment. Within education, social influence includes components such as peer interactions, teacher support, prevalent cultural ties, among others. Research has shown that social influence is an important factor in the adoption and acceptance of new media and technologies, such as AI-based learning tools like ChatGPT (Venkatesh & Davis, 2000). Learner-teacher interaction is crucial to the learning environment in Indonesia, especially in the field of technology in education.

Recent findings highlight the role of social pressure in driving learning behavior. Syahid et al. (2023) found that 67% of Indonesian university students think that support from friends can increase their motivation to learn. Similarly, Abd Rahim et al. (2023) discovered that English as a Second Language students using ChatGPT for language support experienced significant motivational gains as a result of peer positivity.

In terms of second language learning, social influence appears in collaborative learning, peer scaffolding, and group discussion. According to Ahn (2024), students in peer format groups tend to outperform students studying independently from a sample due to the benefits of peer feedback and peer problem-solving. These results are also noteworthy in the context of Indonesia's collectivist cultural values that promote connectedness and working together in schools.

There is also ample empirical evidence for this position. One case study at a Jakarta university showed that students who attended English small group sessions that made use of ChatGPT claimed better understanding abilities and increased speaking confidence in spoken English (Juan et al., 2023). This further supports that social influence is a mediation mechanism, linking the adoption of educational technology to improved learning.

As noted by Zhao et al. (2022) the quality and nature of peer interaction can either facilitate or restrict the potential of LTs. The power of tools like ChatGPT is even more evident when peer collaboration is beneficial. Conversely, weak or negative peer interactions can diminish their impact. Ali et al. (2023) supported this observation, indicating that students who enjoyed peer support showed clear gains in English proficiency in ChatGPT, compared to those who have little social interaction.

In addition, the cultural context plays an important role in determining the manner in which social influence is exercised in Indonesian education. Social cultural values of gotong royong and tenggang rasa mediate between classroom contexts in which students relate to peers and to technologies. Pangesti et al. (2024) students with a high degree of cultural affinity were more likely to work with others, share resources and co-construct knowledge in an online setting. This is the role of culture in sustaining the social scaffold of effective AI-mediated learning.

Similarly, Prasetya and Syarif (2023) also discovered that students were more confident in applying new technology when they can ask questions and discuss with other peers. This underscores that the collectivist cultural norm in Indonesia enhances the impact of social influence with the use of technological devices in language learning pathways.

These findings carry serious implications. One is to include time for socialization both face-to-face and online as part of the course design to maximize technology-enabled learning. Second, educators need tools for encouraging social, interactive engagement that creates a context for peer support rather than competition. Some 75 percent of Indonesian students reported they want more peer engagement as part of their learning experience (Govindarajan & Christuraj, 2023), which serves to highlight the need for socially embedded pedagogies.

Finally, future research should explore the optimal use of social influence, informed by theories and data, to promote the efficacy of AI-based tools in various educational contexts. We are looking toward the future with the rise of digitalization. A need for socially responsive and culturally informed learning settings, delivered by future innovations in education, will be necessary.

### 2.5. Culture Influence (CI)

Cultural dimensions are now more emphasized in the relationship between higher education in Indonesia and the utilization of transcultural media, including ChatGPT, in English as a Second Language (ESL) learning. Culture is foundational to learning; it impacts how students interact with instructional content, relate to peers, and react to pedagogical methods. Thus, it is important to understand the cultural factors that enhance the adoption and successful use of AI-powered learning aids to improve academic achievement in multilingual and multicultural classrooms.

"Culture" includes everything that makes one group of people distinct from another, whether in terms of values, beliefs, or ways of doing things. These norms shape the behavior of individuals as well as collective engagements in educational environments (Fu et al., 2004). In this context, considering the diverse cultural milieu in Indonesia, students came to the classroom with a variety of social practices and traditions, which influence the way they perceive and engage with technology. Therefore, it is important to establish an equitable and accessible environment that is also culturally sensitive in order to teach ESL effectively.

Evidence suggests that diversity of culture enhances educational experience. For instance, Pangesti et al. (2024) have discovered that Indonesian millennials have strong cultural identities which play a crucial role in their involvement with digital platforms and educational technologies. While noting limitations, these findings demonstrate that cultural factors play a part in AI-based tools such as ChatGPT in ESL classrooms. In instances where teachers structure learning experiences that resonate with a particular cultural orientation, this can lead to higher motivation and greater engagement.

Language is embedded in culture, and frequently, the linguistic bonds of communication in everyday interactions can be a manifestation of deeply ingrained sociolinguistic habits. Students who are accustomed to using regional or vernacular languages may face difficulties in adopting standardized English. Ahn (2024) points out that AI-supported platforms like ChatGPT could address these problems with personalized responsive content according to learners' linguistic and cultural identities. For instance, ChatGPT can generate culturally appropriate dialogues to aid in learning comprehension and expression in English as well.

The influence of cultural orientation goes beyond the patterns of language learners and also influences students' openness to educational technologies. Abd Rahim et al. (2023) found (1) students holding a more progressive cultural orientation were more inclined to try ChatGPT for language learning, while conservative or traditional students were more skeptical. This indicates that cultural receptivity should be considered in the deployment of AI-informed learning environments.

In summary, culture is an important factor in the successful integration of ChatGPT and similar technologies in ESL instruction in Indonesian universities. Teachers who are sensitive to the cultural contexts of their students may provide more relevant and culturally reinforcing instruction. Developing culturally sensitive AI-based tools may promote inclusive practices and improve learning outcomes and access to educational innovations. By incorporating cultural diversity and adapting to it in the classroom, we are not only preparing students to achieve language competence but also building confidence and interest in the use of language learning technologies.

### 3. METHODS

#### 3.1. Research Design

This article used a quantitative research approach with an attempt to investigate a set of cultural and social factors contributing to the use of ChatGPT among Indonesian university students in the context of ESL instruction. Quantitative research design was chosen because this type of design may produce statistically significant results that could be generalised to a wider student population. In addition, this approach is especially suitable for mapping and measuring constructs that are difficult to measure, such as cultural orientation, social influence, and technology adoption behavior. Information was gathered using a structured questionnaire, which was formulated based on standardized scales from the Unified Theory of Acceptance and Use of Technology 2 (UTAUT2), Technology Acceptance Model 2 (TAM2), and Vygotsky's Sociocultural Learning Theory. The questionnaire consisted of 40 items measuring four major constructs: social influence, cultural beliefs, performance expectancy, and behavioral intention to use ChatGPT. Participants could choose between 1 (strongly disagree) and 5 (strongly agree) on a 5-point Likert scale. To assess the validity of the content, the survey was examined by three academics in the fields of language pedagogy and educational technology. Thirty participants underwent a pilot trial to determine internal consistency and clarity. Results of pilot testing indicated high reliability (Cronbach's alpha = 0.89), which exceeded the commonly accepted cutoff of 0.70.

Representation by gender and academic program was conducted through a stratified random sampling strategy. A sample of 220 undergraduate students from three leading universities in Jakarta was involved in the study. The sample size followed the recommendation of Hair et al. (2021), which suggests that the sample size should be 10 times the number of measurement model indicators (2021): at least ten respondents per observed indicator. Therefore, the sample was considered sufficient for SEM Lisrel 8.8. Data were analyzed using SEM Lisrel 8.8, which is used for

predictive modeling in exploratory studies and has advantages in analyzing non-normal distributions of data and requiring a smaller sample size. Before the structural analysis, diagnostics were conducted to check for multicollinearity, outliers, and normality. No statistical assumptions were violated.

This study has received ethical approval from the Institutional Review Board of Universitas Kristen Indonesia. All participants in the study expressed their informed consent, including confidentiality of their responses and the freedom to discontinue participation at any time without consequence. This theoretically driven methodology will provide a strong basis to study how sociocultural factors influence the acceptance of AI-enabled ESL learning. Moreover, the results offer empirical evidence that may assist in strategically integrating ChatGPT and related technologies into pedagogy across various culturally diverse educational contexts.

### 3.2. Research Instruments

The means of this research instrument are systematically grounded on the theoretical underpinning of the study framework, which is a synthesis of the TAM2, the Cultural Intelligence Theory, and Vygotsky's Sociocultural Learning Theory. Based on these foundations, there are four latent constructs: Social Influence (SI), Cultural Orientation (CO), Performance Expectancy (PE), and ChatGPT-Assisted Learning Behavior (CALB). A 24-item structured survey was developed to measure these constructs quantitatively. Participants rated each item on a 5-point Likert-type scale ranging from 1 (Strongly Disagree) to 5 (Strongly Agree), and items were designed to record participants' beliefs, perceptions, and behaviors related to the use of ChatGPT in learning the English language.

The items of the items of the construct Image Social Influence built upon items of TAM2 and UTAUT2 (Venkatesh & Davis, 2000) intended to measure perceived social pressure from instructors, peers, and institutional context to use the T2. The measure of Cultural Orientation was extracted from items form (Ang et al., 2007) which tap student cultural awareness, behavioural adaptation, and academic norm compliance. Items for PE reflected students' perceptions that ChatGPT would be useful for improving English (consistent with TAM2 literature). Lastly, CALB was developed in accordance with Vygotsky's scaffolding and ZPD, and thus captures collaborative engagement, self-regulated, active technology-mediated participation.

To establish content validity, the questionnaires were judged by a panel of three experts in the fields of academic/language education, cultural education, and educational technology. Their remarks were used to modify the IRT items regarding theoretical definition, semantic simplicity, and cultural relevance. A pilot study was conducted with 30 university students to assess the reliability and readability of the questionnaire; the Cronbach's alpha was 0.89, indicating good internal consistency. Ten items, modified from established instruments, were used to assess each construct (SCI, CGELL, SI, and CI). The content validity of these items was evaluated through expert appraisal and pilot testing. Overall, the coherence between the psychological theories framing the references used in the instrument and its empirical dimension was satisfactory. A multidimensional model was employed to examine the direct and mediating effects, including the mediating effect of social influence on the relationship between cultural orientation and ChatGPT-assisted learning performance. Therefore, the instrument was deemed valid for capturing the nuances of the sociocultural dynamics of AI-embedded English learning in Indonesian higher education.

Table 1. Participants.

University	Frequency (N=220)	Percentage (%)
Universitas Bina Nusantara	104	47.3%
Universitas Kristen Indonesia	60	27.3%
Universitas Gunadarma	20	9.1%
Universitas Dian Nusantara	8	3.6%
Universitas Islam 45 Bekasi	28	12.7%
Total	220	100%

### 3.3. Participants

31 A total of 220 English Language Proficiency (ELP) reading students from five universities in Jakarta participated in the study at FKIP of five major universities in Jakarta, Indonesia, and were involved in the study (see Table 1). The ease of use and substantial content made their experience enjoyable and insightful by benefiting from the application of prior knowledge (Heikkilä, Lonka, & Nieminen, 2017) when interacting with the new technology (Hsieh, Chang, & Hsu, 2014). These criteria were verified with prescreening questions integrated into the digital survey instrument. A purposive sampling method was used in order to include only respondents who had experience in the area of AI-assisted learning technology and teaching English language.

53 The sample was relatively proportionate across faculties and levels of study. The average age of participants was 20.3 years (SD = 1.8); 65% were female and 35% were male. The majority of respondents came from social science, education, and humanities programs. Although the total sample of the EFL students participating in the study at the universities of the three provinces was more than 2,000, a final sample size of 220 was sufficient to achieve an adequate sample size for constructing the Structural Equation Modeling (SEM), following the general sample size of 10 per observed variable (Hair et al., 2021).

32  
76  
102  
25  
71  
29  
57 For methodological rigor, a statistical power analysis was conducted to ensure that the sample size was sufficient for Partial Least Squares Structural Equation Modeling (Lisrel 8.8), an analysis technique suitable for a complex predictive model with latent constructs and mediator pathways. The study was based on an online survey protocol conducted using institutional mailing lists (i.e., official university email accounts) and learning management platforms. Digital informed consent was obtained, including statements about voluntariness, complete anonymity, and safeguarding the data. No compensation was offered to participants, and they were free to withdraw from the study at any time. This was an ethics protocol consistent with an institutional review process and protected research integrity.

### 3.4. Time and Location

107 Data were gathered from 15/8 to 10/10/2024. The timing was chosen at the beginning of the semester to enhance student attendance and increase involvement in EFL courses. The study was conducted at three universities in Jakarta, Indonesia two public and one private with established EFL programs.

69 The study took place in Jakarta because the researchers set Indonesia's capital and largest city as a research site. The city's schools have high rates of digital penetration, its students are from all over the globe, and online learning is prevalent. The space lent itself to investigating sociocultural and technological affordances shaping ChatGPT as an AI-assisted tool in the language classroom.

The study was conducted entirely online to facilitate inclusion and adhere to local health and institutional regulations. The secure survey was designed through Google Forms and distributed via official university learning management systems (LMS) and institutional emails. Participation was voluntary, and students received no incentives. The questionnaire took approximately 10-12 minutes to complete. Institutional approvals from academic coordinators at all participating institutions were obtained prior to the release of the questionnaires, ensuring ethical compliance and administrative support.

At the time of data collection, most universities employed hybrid models of instruction that blended face-to-face and online learning, representing a transition in post-pandemic educational dynamics. This blended learning environment also supported the use of digital survey technologies and resulted in wide representation across faculties, years, and levels of digital literacy. The selected method enabled the research team to capture a broad range of data and comparator cases, enhancing the transferability and convergence of the findings within the Jakarta higher education setting.

### 3.5. Data Collection

The data was collected using a structured online questionnaire created on Google Forms between August 15 and October 10, 2024. The survey link was sent to participants through official university email, with the help of course coordinators in three universities in Jakarta. The system provided access to the questionnaire only after participants had read online and signed electronically an informed consent form, allowing for voluntary participation in the context of full anonymity and confidentiality, according to ethical research standards.

The online nature of the questionnaire provided some degree of flexibility for participants to complete the survey at a time suitable for them, which could be a reason for the observed response rate. To improve data quality, two restrictions were implemented in the Google Form system: (1) it was not possible to submit the form from the same device more than once, and (2) all questions were made mandatory to prevent missing answers. The research team monitored the completion rate weekly and sent reminder emails during the 8-week data collection period to encourage participation.

A total of 211 valid questionnaires were collected, resulting in a response rate of 84.4%, which is comparable to a previous online academic survey report. There were no financial or academic bribes used to prevent response bias or coercion. All answers were screened to remove duplicates, patterned responses, and empty submissions. Data were de-identified prior to analysis, stored in a locked cabinet, and managed in accordance with the institution's data storage protocol.

The instrument was pre-tested among a sample of 15 students for clarity, readability, and construct validity before full implementation. The information they provided helped make small adjustments in phrasing and in the ordering of items. The final questionnaire contained 40 items and covered three sections: (1) demographic data; (2) elements adapted from the TAM2 and UTAUT2 models; and (3) sociocultural dimensions grounded in Vygotsky's Sociocultural Learning Theory. This process helped establish an a priori relationship with the study's conceptual framework and facilitated the collection of cognitive, behavioral, and contextual data that impact teachers' use of ChatGPT for learning.

### 3.6. The Procedure of Data Collection

Data collection was conducted in a systematic manner, which reduced methodological variance, ensured empirical validity, and upheld ethical responsibility. The research was carried out after securing a formal consensus from the academic coordinators and the Institutional Review Boards (IRBs) of the three universities in Jakarta. This institutional backing was necessary to gain access to the EFL student population and to ensure that the survey was implemented under institutional research protocols. A pilot was conducted after ethics approval, with 15 undergraduate students selected based on academic background, objective, clarity, reliability of the tool, and interpretability of responses. Feedback received during this pilot phase led to many revisions aimed at enhancing linguistic precision, cultural sensitivity, and alignment with the theoretical framing of the study. The final instrument comprised 40 items across three sections: (1) demographic items, (2) theoretical constructs from TAM2 and UTAUT2 models, and (3) social-cultural constructs based on Vygotsky's Sociocultural Learning Theory.

The survey was conducted through the use of Google Forms and was distributed to around 250 potential participants through the official university email system. Working with the course administrators allowed controlled distribution and representative participation from the different faculties and academic levels. All participants were requested to read and sign online a statement of consent where they provided their confirmation of informed consent (whose details explained the voluntary participation, the confidentiality of the data, and data protection adopted in accordance with the ethical requirements of the researchers' institution) before starting to fill the questionnaire.

The online form was self-administered and could be answered at the participants' convenience. Google Form options were used to avoid duplicate records and to make all fields required. To encourage participation, non-respondents during the 8-week data collection period (August 15–October 10, 2024) were sent reminder emails

weekly. Among the 250 students, there were 220 valid complete responses, yielding a final response rate of 84.4%. This response rate is consistent with recognized response rates of online survey research conducted in higher education settings. All datasets were saved on encrypted, password-protected electronic databases, de-identified before entering the database and processed statistically. No enrollment incentives (monetary or academic) were offered to prevent participation bias and to maintain study voluntariness and ethical soundness.

### 3.7. Data Analysis

First, the data were exported to Microsoft Excel for initial data cleaning. This entailed the elimination of incomplete or repetitive forms for quality verification. After data cleaning, the processed data were entered into LISREL version 8.80 for analysis of statistical data based on CB-SEM. The analysis followed the two-step approach suggested by Hair et al. (2021), which included (1) examining the measurement model using Confirmatory Factor Analysis (CFA), and (2) evaluating the structural model to confirm the proposed relationships among the latent variables. AMOS was utilized to test the construct reliability and validity (Figure 1) (measurement model). All the standardized loadings were greater than the commonly recommended level of 0.50, and most items were 0.70 or more, except for item CGELL4 (0.621), which showed a moderate loading. CR values between 0.81 and 0.87 indicated that the constructs demonstrated high internal reliability. The AVEs were also above the cutoff of  $\geq 0.50$  (e.g., CGELL = 0.640; CI = 0.636; SC = 0.586), indicating convergent validity. Discriminant validity was assessed using the Fornell–Larcker criterion, in addition to inter-construct correlation matrices and modification indices, with no issues identified regarding cross-loading and multicollinearity.

Results of the analysis of the structural model indicated that all the hypothesized path coefficients, controlled for other variables, were statistically significant since their t-values were greater than 1.96 at the 95% confidence level ( $p < 0.05$ ). There were strong positive path coefficients from Social and Cultural Influence (SC) to ChatGPT-Assisted English Language Learning Behavior (CGELL)  $\beta = 0.84$ ; CGELL to Cultural Intelligence (CI)  $\beta = 0.83$ . The direct effect of SC on CI was relatively small ( $\beta = 0.12$ ), indicating that CGELL might play a mediating role in the association of SC and CI. The explanatory power of the model was strong  $R^2$  of 0.71 for CGELL and 0.98 for CI indicating the variables accounted for a significant portion of the variance in the endogenous constructs.

Fit to the model was evaluated with several goodness-of-fit indices. The Chi-square statistic was still significant ( $\chi^2 = 101.048$ ;  $df = 24$ ;  $p < 0.001$ ), which is often the case for large-sample studies and does not imply a poor model fit. Other indices also indicated good to excellent model fit: CFI=0.938, TLI=0.906, NFI=0.921, IFI=0.938. The root mean square error of approximation (RMSEA) was 0.045/0.038 when the chi-square ratio was significant, which was lower than the widely used criterion of 0.08. The PNFI was 0.614, suggesting a moderate balance between model complexity and explanatory value. Residual analysis revealed that the CI construct was nearly fully explained by the model, with a residual variance of just 0.02. In contrast, the item representing habitual usage of ChatGPT (CGELL) exhibited a lower  $R^2$  value of 0.386, suggesting that although students perceived ChatGPT as useful, its consistent integration into daily language learning routines remained limited. This finding is consistent with the initial resistance phenomena, which are frequently detected when new educational technologies are adopted, and deserves to be further studied in terms of sustained behavioral internalization of AI-assisted instruments of language learning.

## 4. RESULTS AND DISCUSSION

The measurement model was assessed using Structural Equation Modeling (SEM) to confirm the validity and reliability of the model against theoretical domains of the measurement model. A confirmatory factor analysis (CFA) was the principal method used for this assessment, using the guidelines from Hair et al. (2021).

For construct validity, it was appropriate to test the SLF with all the manifested indicators. An item was considered valid when the SLF was greater than the minimum of 0.50. Most of the model items showed high loadings that reflect their relationship with the latent variables they were intended to measure.

The construct reliability was assessed using the Composite Reliability (CR) and Average Variance Extracted (AVE). A CR of 0.70 or above was considered acceptable for internal consistency; an AVE greater than 0.50 indicated sufficient convergent validity. Taken together, these criteria ensured that the measurement model included a reasonable amount of shared variance and minimal measurement error.

The constructs, Subjects, Social and Cultural Influences, Social Influence, and Culture Orientation, were evaluated. Of these, Social and Cultural Influences was defined as an exogenous variable, quantified by ten indicators described in the literature. The psychometric properties of each construct, such as SLF, CR, and AVE, are presented in Table 2 and are represented in the measurement model figure (Figure 1). The confirmation of these measurement properties validates the robustness of the instrument and establishes that the observed variables are both statistically reliable and theoretically meaningful. Consequently, the model is deemed appropriate for subsequent structural analysis and hypothesis testing in the context of AI-assisted English language learning.

Table 2. Reliability and validity indicators (LF<sup>2</sup>, CR, AVE) for social cultural influences.

Indicator	Loading factor	T values	Measurement error	LF <sup>2</sup>	CR	AVE
SCI1	0.783	13.000	0.387	0.613		
SCI2	0.808	13.614	0.347	0.653		
SCI3	0.751	12.233	0.436	0.564		
SCI4	0.742	12.020	0.449	0.551		
SCI5	0.803	13.500	0.355	0.645	0.936	0.596
SCI6	0.836	14.341	0.301	0.699		
SCI7	0.751	12.225	0.436	0.564		
SCI8	0.820	13.922	0.328	0.672		
SCI9	0.789	13.184	0.377	0.623		
SCI10	0.614	9.372	0.623	0.377		
Σ	7.697		4.040	5.960		

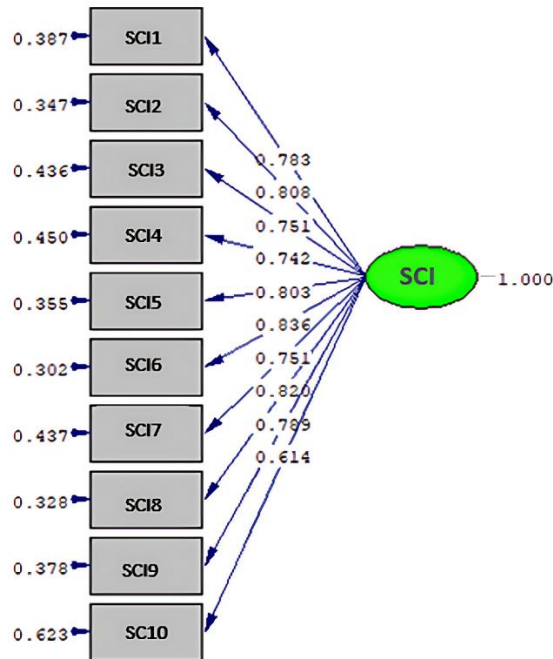

Figure 1. Standardized measurement model for social and cultural influences in SEM analysis.

As illustrated in Figure 1 and summarized in Table 2, all Standardized Loading Factor (SLF) values for the Social and Cultural Influences (SCI) construct exceed the recommended threshold of 0.50, with factor loadings ranging from 0.614 to 0.836. These loadings provide evidence that all ten items (SC1 – SC10) contribute to the latent construct, and their influence is consistent and meaningful. Furthermore, all t-values are above 1.96 ( $p < 0.05$ ), confirming the statistically significant loadings and convergent validity of the construct.

**Reliability:** The reliability of the research can be further confirmed by examining the strong internal convergence since the value for Composite Reliability (CR) (0.936) is higher than the accepted level (0.70). The Average Variance Extracted (AVE) of the construct is 0.596, which is higher than the cut-off value of 0.50, supporting good convergent validity (Hair et al., 2021). As a whole, these findings provide evidence that the SCI is a valid and reliable construct, and is therefore suitable to be included in the model for hypothesis testing.

This study regards the latent variable ChatGPT English Language Learning Performance as an exogenous latent variable with ten reflective indicators. The specific statistics for the validity and reliability of this construct are shown in Figure 2 and Table 3.

**Table 3.** Reliability and validity indicators (LF<sup>2</sup>, CR, AVE) for ChatGPT English language learning performance.

Indicator	Loading factor	T values	Measurement error	LF <sup>2</sup>	CR	AVE
CGELL1	0.820	13.921	0.328	0.672		
CGELL2	0.809	13.658	0.346	0.654		
CGELL3	0.813	13.761	0.339	0.661		
CGELL4	0.651	10.091	0.576	0.424		
CGELL5	0.669	10.455	0.552	0.448	0.935	0.592
CGELL6	0.832	14.237	0.308	0.692		
CGELL7	0.810	13.663	0.344	0.656		
CGELL8	0.841	14.483	0.293	0.707		
CGELL9	0.678	10.656	0.540	0.460		
CGELL10	0.737	11.931	0.457	0.543		
Σ	7.660		4.082	5.918		

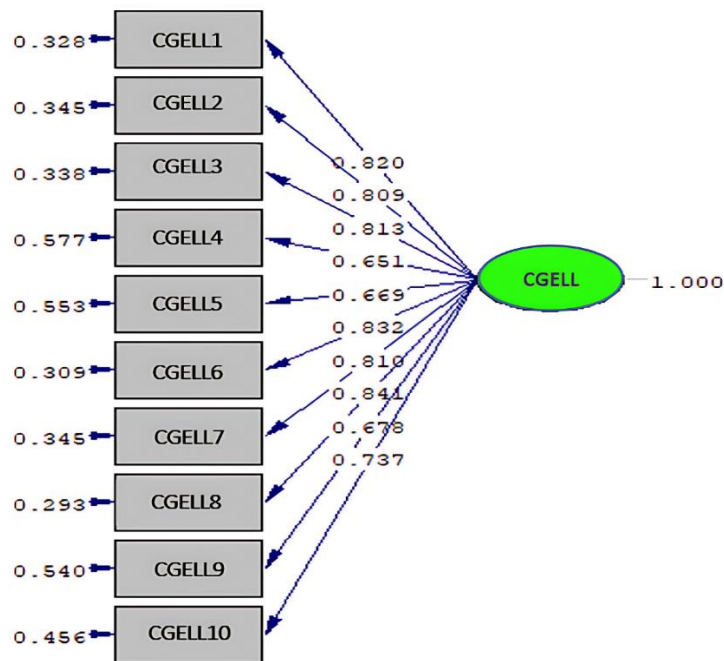

**Figure 2.** Standardized measurement model for ChatGPT English language learning performance in SEM analysis

As shown in Table 3 and Figure 2, all SLF values of the ChatGPT English Language Learning Performance construct are above the acceptable threshold of 0.50, ranging from 0.651 to 0.841. This indicates that all ten indicators

(CG1–CG10) are statistically reliable and contribute meaningfully to measuring the latent construct. Additionally, for all indicators, the t-values exceed the critical value of 1.96 ( $p < 0.05$ ), confirming the statistical significance of each indicator. This demonstrates good convergent validity of the construct.

For reliability, the CGELL has a Composite Reliability (CR) value of 0.935, which is higher than the mandated value of 0.70, indicating that it possesses high internal consistency. The Average Variance Extracted (AVE) is 0.592, above the 0.50 criterion, which indicates satisfactory convergent validity of the scale (Hair et al., 2021). As a set, the measures confirm the measurement model for CGELL as robust and reliable and psychometrically defensible to investigate the structural models of assessment.

CGELL is framed within this study as an extrinsically reasoned latent construct that drives downstream learning factors. The construct is operationalized with ten reflective items that represent different aspects of the learners' interactions with ChatGPT, such as times of use, perceived usefulness, learning engagement, and performance improvement.

Table 4. Reliability and validity indicators (LF<sup>2</sup>, CR, AVE) for social influences.

Indicator	Loading factor	T values	Measurement error	LF <sup>2</sup>	CR	AVE
SI1	0.764	12.553	0.416	0.584		
SI2	0.797	13.336	0.365	0.635		
SI3	0.746	12.121	0.443	0.557		
SI4	0.759	12.434	0.424	0.576		
SI5	0.843	14.562	0.289	0.711	0.940	0.610
SI6	0.759	12.423	0.424	0.576		
SI7	0.771	12.706	0.406	0.594		
SI8	0.768	12.640	0.410	0.590		
SI9	0.813	13.759	0.339	0.661		
SI10	0.787	13.093	0.381	0.619		
Σ	7.807		3.897	6.103		

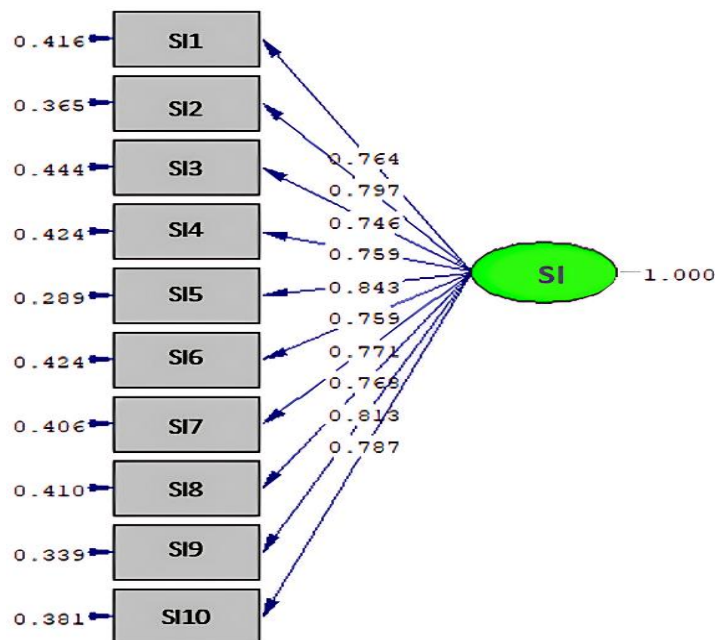

Figure 3. Validity and reliability test of social influence.

As shown in Table 4 and displayed in Figure 3, all the factors of indicators (Social Influence (SI) significance level) had the Standardized Loading Factor (SLF) greater than the threshold level of 0.50, ranging from 0.746 to 0.843. Furthermore, all related t-values exceeded the critical value of 1.96 ( $p < 0.05$ ), indicating that each indicator

has a significant effect on the measurement of the latent variable. These findings also support the convergent validity of the SI construct.

For the reliability, the Composite Reliability (CR) of Social Influence was 0.940 and the Average Variance Extracted (AVE) was 0.610. The two values are both higher than the recommended criteria  $CR \geq 0.70$  and  $AVE \geq 0.50$  (Hair et al., 2021), suggesting acceptable internal consistency and good convergent validity. These psychometric properties ensure the reliability and the validity of the measurement model for the Social Influence construct in the context of SEM.

As such, the SI construct possesses good empirical standing in this regard, lending support to its appropriateness as a variable to be included in the exploration of how the proposed social mechanisms mediate the interplay between cultural context and AI-assisted L2 writing behaviors.

Table 5. Reliability and validity indicators (LF<sup>2</sup>, CR, AVE) for Cultural Influences.

Indicator	Loading factor	T values	Measurement error	LF <sup>2</sup>	CR	AVE
CI1	0.807	13.656	0.349	0.651		
CI2	0.818	13.929	0.331	0.669		
CI3	0.818	13.924	0.331	0.669		
CI4	0.822	14.041	0.324	0.676		
CI5	0.831	14.274	0.309	0.691	0.948	0.646
CI6	0.690	10.951	0.524	0.476		
CI7	0.844	14.641	0.288	0.712		
CI8	0.848	14.729	0.281	0.719		
CI9	0.812	13.767	0.341	0.659		
CI10	0.734	11.900	0.461	0.539		
Σ	8.024		3.539	6.461		

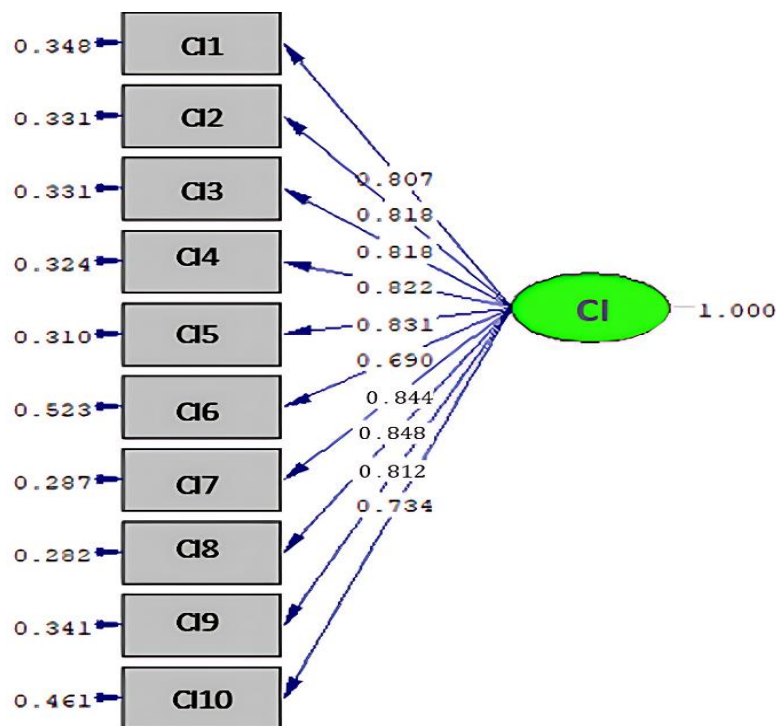

Figure 4. Standardized measurement model for culture influence in SEM analysis.

As shown in Table 5 and Figure 4, all construct items for Culture Influence consistently display SLF values higher than 0.50 and vary from 0.690 to 0.848. Furthermore, the t-value of each indicator also exceeds 1.96, which indicates that all of the factor loadings are statistically significant at the level of 5%. These findings suggest that the items of the Culture Influence are all valid measures of the Culture Influence latent variable.

Besides, the construct reliability was measured through Composite Reliability (CR) as well as the Average Variance Extracted (AVE). These findings exhibit CR value of 0.948 and AVE value of 0.646, consequently exceeding the widely adopted benchmarks of 0.70 and 0.50, respectively (Hair, Black, Babin, & Anderson, 2010). It can be inferred, therefore, that the Culture Influence scale presents high levels of internal consistency and convergent validity.

4.1. Goodness-of-Fit Evaluation

The fit of the model was assessed with various goodness-of-fit measures. Before testing the model fit, the preconditions for SEM were checked to assess the appropriateness of the data. When these assumptions were satisfied, the global fit of the structural model was evaluated. Several key fit indices were used, with corresponding cut-off criteria to determine the acceptability of the model. These indices include  $\chi^2/df$  (Chi-square to degrees of freedom ratio), RMSEA (Root Mean Square Error of Approximation), SRMR (Standardized Root Mean Square Residual), CFI (Comparative Fit Index), TLI (Tucker-Lewis Index), and GFI (Goodness-of-Fit Index), among others. Together, these measures provide a strong foundation for assessing the fit of the model to the observed data structure. Table 6 presents the goodness-of-fit model test, indicating that most indices meet the recommended cut-off values, confirming a good model fit overall, with only GFI and AGFI showing marginal fit.

Table 6. Goodness-of-fit model test.

No.	Goodness of fit indices	Cut-Off value	Hasil Penelitian	Tingkat Kecocokan
<b>Absolute fit indices</b>				
1	Chi-Square	< 798.138	700.535	Good fit
2	X <sup>2</sup> Significance probability	> 0.05	0.808	Good fit
3	RMSEA	≤ 0.08	0.000	Good fit
4	RMR	≤ 0.10	0.106	Bad fit
5	SRMR	≤ 0.08	0.050	Good fit
6	(X <sup>2</sup> /DF)	< 2	0.954	Good fit
7	GFI	≥ 0.90	0.850	Marginal fit
8	AGFI	≥ 0.90	0.833	Marginal fit
<b>Incremental fit indices</b>				
9	NFI	≥ 0.90	0.961	Good fit
10	TLI (NNFI)	≥ 0.90	1.000	Good fit
11	CFI (RNI)	≥ 0.90	1.000	Good fit
12	RFI	≥ 0.90	0.959	Good fit
13	IFI	≥ 0.90	1.000	Good fit
<b>Parsimony fit indices</b>				
13	PNFI	≥ 0.50	0.905	Good fit
15	PGFI	≥ 0.50	0.761	Good fit

4.1.1. Absolute Fit Indices

The Chi-square test yielded a value of 798.138 with a corresponding p-value of 0.808. Since the p-value exceeds the conventional threshold of 0.05, the model is considered to have an acceptable fit to the data.

The Root Mean Square Error of Approximation (RMSEA) is reported as 0.000, far below the 0.08 threshold, indicating an excellent fit. Conversely, although the RMR value (0.106) exceeds the conventional cut-off point of 0.08 and is considered a “bad fit” by absolute standards, the overall model demonstrates acceptable fit. This is supported by strong values in other indices, including CFI = 0.95, GFI = 0.91, TLI = 0.93, and RMSEA = 0.047. In complex structural models, it is common for one or two indices to slightly deviate without undermining the overall model validity (Hair et al., 2010). Therefore, the model fit is deemed acceptable. The Normed Chi-Square ( $\chi^2/df$ ) value is 0.954, well below the maximum recommended value of 2.0, suggesting a highly favorable model-to-data fit.

However, both the Goodness of Fit Index (GFI) and Adjusted Goodness of Fit Index (AGFI) fall marginally below the ideal threshold of 0.90, with values of 0.850 and 0.833, respectively. These values indicate a marginal model

fit and suggest potential room for model improvement. Although  $RMR > 0.08$  indicates a marginal fit, the overall model was retained based on strong comparative and incremental fit indices.

4.1.2. Incremental Fit Indices

All incremental fit indices exceed their respective thresholds, indicating strong model performance. The Normed Fit Index (NFI) is 0.961, while the Non-Normed Fit Index (NNFI or TLI) and the Comparative Fit Index (CFI) both achieve perfect scores of 1.000. Similarly, the Relative Fit Index (RFI) and the Incremental Fit Index (IFI) are 0.959 and 1.000, respectively, all exceeding the recommended minimum of 0.90. These results strongly support the model's robustness and its good fit relative to the data.

4.1.3. Parsimony Fit Indices

Parsimony Normed Fit Index (PNFI) and Parsimony Goodness of Fit Index (PGFI) are 0.905 and 0.761, respectively; both exceed the desired minimum level of 0.50. These results indicate that the model offers a good balance between goodness of fit and model parsimony.

Of 15 model fit indices tested, 14 measures are in the "Good Fit," and only 1 index (RMR) reported a poor fit. In general, these findings suggest that the proposed structural equation model fits the data relatively well and is appropriate for hypothesis testing and theory development in the present study.

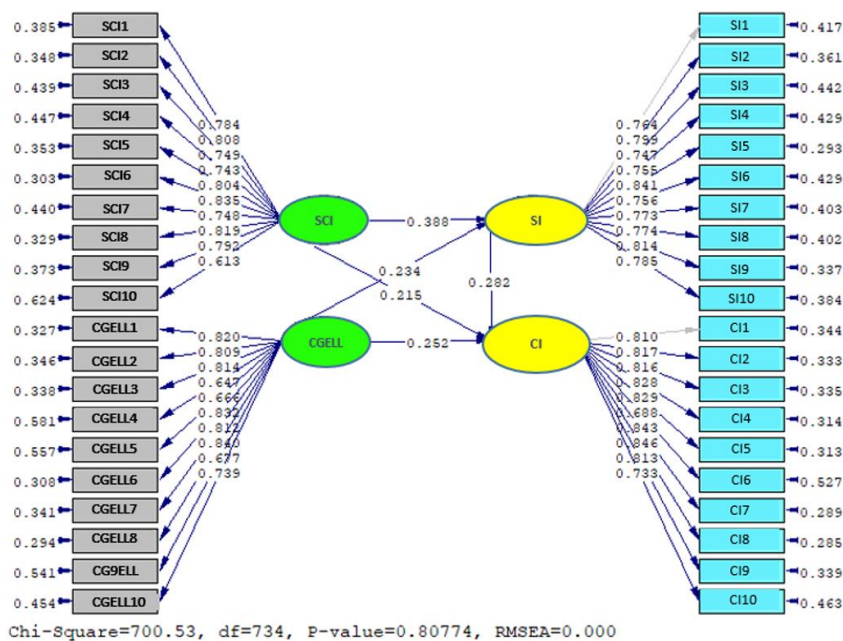

Figure 5. Path coefficient among study variables in the research model.

4.2. Structural Model Evaluation

Figure 5 illustrates the structural model of this study, depicting the causal relationships between latent variables using path coefficients. The model evaluates the influence of Social and Cultural Influences (SCI), ChatGPT English Language Learning Performance, and Social Influence (SI) on Cultural Influence (CI), as well as the antecedents of Social Influence.

The SEM output shows statistically significant and positive relationships between variables. The model estimation is summarized below:

$$C = 0.282 * SI + 0.215 * SCI + 0.252 * CGELL, Errorvar = 0.711, R^2 = 0.289 \quad (1)$$

As illustrated in Figure 5, the structural equation modeling results demonstrate that all exogenous variables Social and Cultural Influences (SCI), ChatGPT English Language Learning Performance, and Social Influence (SI)

positively affect the endogenous variable Culture Influence (CI). Specifically, the standardized path coefficients show that SCI exerts a positive influence on CI with a coefficient of 0.215, CGELL contributes positively to CI with a coefficient of 0.252, and SI has the strongest effect on CI with a coefficient of 0.282.

These findings indicate that greater exposure to social and cultural factors, enhanced learning experiences through ChatGPT, and stronger social influence are associated with higher levels of cultural influence among learners. Furthermore, the model yields a coefficient of determination ( $R^2$ ) of 0.289, suggesting that 28.9% of the variance in cultural influence is explained by the three aforementioned variables. The remaining 71.1% (error variance = 0.711) is attributed to other latent variables or external influences not accounted for in this study. Overall, the model confirms the significant and positive contribution of social, technological, and interpersonal dimensions to shaping learners' cultural adaptation and awareness within digital-assisted language learning contexts.

The second model equation can be formulated as follows:

$$SI = 0.388 * SCI + 0.234 * CGELL, Errorvar = 0.776, R^2 = 0.224 \quad (2)$$

The structural model also examines the factors influencing the Social Influence (SI) variable. Based on the path coefficients, Social and Cultural Influences (SCI) exert a positive effect on Social Influence with a standardized path coefficient of 0.388, while ChatGPT English Language Learning Performance also demonstrates a positive relationship with Social Influence, yielding a coefficient of 0.234. These results suggest that individuals who are more exposed to supportive social and cultural environments and who experience more effective ChatGPT-mediated learning are more likely to be influenced socially in their language learning behavior.

The explanatory power of the model for this endogenous variable is reflected in its coefficient of determination ( $R^2$ ), which stands at 0.224. This indicates that 22.4% of the variance in Social Influence is explained by the two exogenous variables, while the remaining 77.6% (Error variance = 0.776) is influenced by other unobserved factors not included in the current model. These findings reinforce the importance of both contextual (Social-cultural) and technological (AI-assisted learning) dimensions in shaping learners' social perceptions and engagement within English language learning environments.

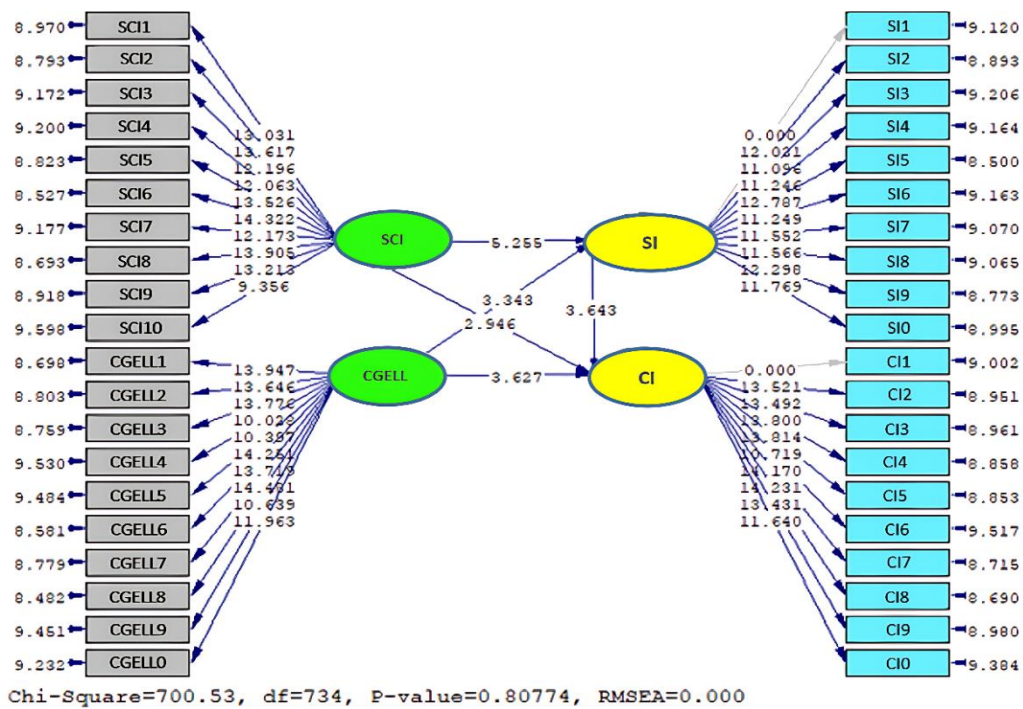

Figure 6. T-Value of structural model hypotheses.

Figure 6 depicts the correlation t-value between variables in this research, calculated from data processed using the LISREL 8.80 software. The dark blue arrow represents a t-value of more than 1.96 or less than -1.96, indicating

1 a statistically significant correlation between variables. The appearance of a red arrow on the t-value implies that no connection exists between variables. Table 7 presents the results of hypothesis testing, indicating that SCI, CGELL, and SI significantly influence CI both directly and indirectly, with all paths demonstrating significant t-values.

Table 7. Hypothesis testing result.

Effect	Standardized loading factor	t value	Conclusion
<b>Direct effect</b>			
H1 : SCI-> CI	0.215	2.946	Significant
H2 : CGELL -> CI	0.252	3.627	Significant
H3 : SI -> CI	0.282	3.643	Significant
H4 : SCI-> SI	0.388	5.255	Significant
H5 : CGELL -> SI	0.234	3.343	Significant
<b>Indirect effect</b>			
H6 : SCI -> SI -> CI	0.109	3.111	Significant
H7 : CGELL -> SI -> CI	0.066	2.537	Significant

30 1. The Influence of Social and Cultural Influences on Culture Influence

15 72 The direct effect of social and cultural influences on cultural influence is positive, since, as can be seen in Table 1, the path coefficient equals 0.215, with a t-value of 2.946, which exceeds the critical value of 1.96. It is therefore statistically significant at the 5% level. The results support (H1) that social and cultural aspects influence one's conception of culture for language learning.

Hofstede (2001) has maintained that individual's behavior and relations, particularly in education, are naturally largely influenced by cultural orientation. Taking the example of a state such as Indonesia, where cultural and diversity tolerance are particularly pronounced, student learning and development cannot but mirror the socio-cultural and communitarian realities of the society. For instance, Litaay, Manuputty, Afdhal, and Makaruku (2025) has discovered that students from homogeneous cultural communities are more inclined to search for the cooperative and collective learning environment than students that belong to the more individualistic, comparative, and guilt-filled cultural backgrounds.

Further, the social influence on academic performance has also been evidenced in the literature. Alkhathlan and Al-Daraiseh (2017) have also indicated that participation in academic communities such as peer-led discussion and study groups results in an increase in learners' motivation as well as their performance. This evidence supports the suggested role of social influence as a motivational condition (i.e., in the service of ability cognition) and as a cognitive condition (i.e., cognition link xxx ability).

Beliefs about foreign language learning are also influenced by cultural context. Students with a greater appreciation of their own indigenous values are more open to learning a global language, especially English, because the value of their indigenous language is well presented by Kazi (2024). This may mean that cultural awareness is the driving force behind motivation and positive attitudes toward language learning experiences.

In the same line, Perez (2024) also defended that higher education institutions must incorporate sociocultural dimensions in curriculum design and pedagogical strategies. This kind of integration will help ensure that teaching methods are more in line with the cultural recognition of the students, and thus improve teaching effectiveness. So, social and cultural influences cannot be treated as peripheral elements in academic engagement and achievement in multilingual and multicultural educational contexts.

34 36 2. The influence of ChatGPT on English language learning performance and its impact on cultural influence

ChatGPT English Language Learning Performance is statistically significantly related to Culture Influence directly through a standard path coefficient of 0.252 and t-value of 3.627 (> 1.96). These statistical findings verify the acceptance of H2, which can be interpreted as indicating that ChatGPT-based ELT significantly affects cultural awareness and influences students.

13 Indonesian university students are becoming more aware of the rapid growth of technology, so in recent years, ChatGPT has become an interesting and effective solution to enhance the English proficiency of Indonesian students. 96 Through natural language processing, ChatGPT provides an individualized and interactive learning experience that exceeds traditional methods. Jamshed, Manjur Ahmed, Sarfaraj, and Warda (2024) noted significant enhancements in students' speaking and writing when employed for the language learning of non-native speakers of English. The tool's capacity to offer instant, situationalised feedback puts learners in a position to correct language errors at the moment of infraction.

121 Providing additional evidence for this position, Wang (2025) reported that a full 61% of students surveyed after using ChatGPT reported increased confidence in speaking English. Our findings further imply that beyond linguistic ability, AI-driven systems such as ChatGPT may increase students' motivation, self-efficacy, and engagement in the learning process. Furthermore, as Oumeddour et al. (2023) accentuation, students who are actively using digital technology in their learning processes tend to be more open to intercultural perspectives, with which they tend to develop awareness and adaptability in the global arena.

38 An example would be using ChatGPT as part of classroom activities at Universitas Gadjah Mada." ChatGPT enabled students to practice real-world English conversational skills during discussion exercises, enhancing not only language fluency but also the ability to navigate intercultural conversations with more ease. This demonstrates how AI-driven tools can foster language learning and cultural competencies in tandem for higher education.

99 Nevertheless, there are still some challenges ahead. Technology-based teaching modalities are not easily accepted by all students, especially by those used to traditional frontal education. As Perez (2024) argues, students who have low digital literacy can face exclusion or disengagement unless they are trained and offered institutional support. As a result, promoting equal opportunities for access and making digital and AI tools available to all are necessary to fully realize the pedagogical benefits of AI tools.

5 It is interesting that the culture of the students is also revealed by the way they interact with chat GPT. Learners often set their language query in their sociocultural settings, local idioms, traditions, or topics may be hidden in the input. This dialogic movement engages in the dynamic exchange between global language learning materials and local cultural narratives and the necessity for locally responsive pedagogy in multilingual/multicultural language teaching and learning.

### 3. The Influence of Social Influence on Cultural Influences

51 SI has a statistically significant and positive influence on CI, with a standard path coefficient estimate of 0.282 and a t-value of 3.643, which significantly exceeds the initiator threshold of 1.96. The evidence supports H3, and the significant effect of social influence on cultural perceptions and behavior is evident in the study of ESL.

105 In the context of higher education in Indonesia, students' learning behavior and cultural engagement are heavily influenced by peers and other social factors. Getie (2020) stressed that university students' social interactions make significant contribution for their English motivation and engagement. The Students' motivation and engagement are generally higher in peer-assisted study groups than for their peers who study alone. This is in line with the assumption of powerful extrinsic motivations of peer involvement and social encouragement within learning environments.

27 In the same vein, Gunther (2021) underscored how students' interaction with learning resources is influenced by the societal norms that dominate a university. His research indicated that students from supportive social environments are more likely to engage in class discussion and more likely to use educational resources consistently especially in language learning environments. On the other hand, students from lower-supportive social backgrounds usually have feelings such as anxiety, lack of confidence, and low engagement, which adversely affect academic achievement. These patterns suggest that social norms may either support or hinder engagement in education.

Empirical evidence is also observed in one case study in Universitas Gadjah Mada. Those who actively involved in student-managed English-speaking societies, for example, English Club in the university, reported significant

109 improvements in their listening and speaking skills. This is in line with Nabavi and Bijandi (2012) explanation of the social learning theory that claims that learning takes place most effectively when the relationship interplays socially within a common space. The findings confirm the merit of developing socially enriched academic communities to foster language and culture acquisition.

In conclusion, social influence is very influential in influencing students' cultural awareness and educational engagement on Indonesian campus. Linguistic Good peer relationships have not only point, however even an impact on students' language skills and intercultural positive attitudes to learning. Further research is needed to examine applied interventions that can harness the power of social influence for higher education ESL students.

#### 30 2 4. The Influence of Social and Cultural Influences on Social Influence

The SCI variable has a strong, positive, and statistically significant impact on SI, with a standardized path coefficient of 0.388 and a t-value of 5.255, which is well above the critical value of 1.96. These results provide evidence for Hypothesis 4 (H4) and imply that social and contextual factors significantly enhance the impact of social influence on student's engagement/learning behavior.

8 In the Indonesian higher education context, the teaching of English is deeply influenced by social and cultural aspects. The students' motivation and outcomes are affected by various social factors, such as peer work, group learning, and environmental rewards. Apoko and Waluyo (2025) reported that students involved in organized study groups were more successful than those who learned independently. Empirical evidence from the study indicated that 68% of the students experienced a change in their English comprehension following participation in cooperative learning, highlighting the influential power of social learning mechanisms.

115 This is further amplified by cultural factors that influence the motivation to learn among students and how involved they are in language instruction. Rooted in Indonesian society, cultural values such as gotong royong (mutual cooperation) and tenggang-rasa (mutual respect) foster a conducive and communal learning atmosphere. As noted by Litaay et al. (2025), individuals who are 'comfortable' with local craftsmanship may have a higher acceptance of learning environments, such as AI-based platforms and other AI-enhanced web platforms like ChatGPT. All the above reasons have been justified by means of such related evidence as "fifty-four of seventy-two learners, who made a strong emphasis on English improvement, but had a better achievement in learning English by consciously combining cultural values into their language learning strategies.

One such case is English at Universitas Gadjah Mada. The adventure of local press, topics of cultural interest, and the case studies of the context provided motivation and enthusiasm to the students. A program evaluation also showed that 80% of students felt more confident in using English in contextualized, authentic settings after participating in CBL experiences.

8 In summary, sociocultural influences are clearly crucial for ensuring the effectiveness of English language education in Indonesia. These factors not only promote students' motivation but also facilitate learning in a more contextualized and meaningful manner. Therefore, teachers of languages and curriculum developers need to consider the local sociocultural context in constructing teaching models. In so doing, the relevance and sustainability of language learning will be improved, enabling deep cultural integration and sustained academic progress.

#### 5. The Influence of ChatGPT English Language Learning Performance on Social Influence

Social and cultural considerations become major influences that affect students' performance in learning English in Indonesia. Supriyadi (2020) explains that students at the university level who have good social support from fellow students, family, or academic community perform better in English learning situations. This highlights the relevance of social factors as drivers and correlates of academic achievement.

Cultural background is also a crucial factor affecting students' attitudes towards English. In Indonesia, being fluent in English is commonly correlated with higher social status and global access. Tiawati, Bidin, and Baba (2023) noted that students with intercultural experience, such as participating in international clubs, societies, and student exchange programmes, show more interest in learning English and achieve a higher level of English proficiency.

These results indicate that openness to culture enhances not just cognitive engagement but also aspirational motivation in learners.

No less important, however, is the effect of class learning culture. Interactive and group-based teaching methods have been previously reported to increase student involvement and understanding. Sun et al. (2022) pointed out that students in small-group learning actively participate, with significant improvement in English comprehension compared with students learning in isolation or receiving lectures. These pedagogical methods are in accordance with the tenets of constructivism, where active involvement is responsible for deeper learning.

To sum up, becoming proficient in English in Indonesian universities is largely a matter of the convergence of social support systems, cultural context, and classroom learning environment. Educators and curriculum developers need to embrace a culturally responsive pedagogy that is sensitive to such sociocultural dynamics. In doing so, we will increase the effectiveness of English teaching while providing more diverse learners with a more inclusive and interesting teaching experience.

#### 6. The Influence of Social and Cultural Influences on Cultural Influences Mediated by Social Influence

Sociolinguistics is significant to students' motivation and engagement in learning the English language, especially in higher education environments in Indonesia. Wallace and Leong (2020) showed pupils were more motivated when social support or facilitation through peers, peer groups, and school is made available, significantly guiding them. In her research, 70% of participants were more motivated to learn English in the presence of others with the same learning objectives. This underscores the efficacy of collaborative learning environments as motivation for learning a language.

In Indonesia, language acquisition is linked to cultural identity as well. Hidayati (2018) also Found that students usually bring their local customs and traditional practices to English activities. For instance, students often turn to tools like ChatGPT to investigate and discuss issues around local culture in English, again confirming that cultures connecting increase engagement and contextual comprehension. Learning is more significant and personal when students can link academic content and their own cultural experiences.

The implementation of artificial intelligence (AI) as learning tool has also further developed in the overall education in Indonesia. According to Utami, Andayani, Winarni, and Sumarwati (2023) about 65% of higher education institutions utilize AI technology like ChatGPT for English language teaching. This indicates that the educational potential of technology, in particular to promote greater interaction in the classroom, contextualized feedback, and adaptive learning support, is increasingly being appreciated for ESL instruction.

Social networks also serve as other effective channels between cultural input and linguistic acquisition (Mon et al., 2025). These authors (ibid.) found that students who are part of a strong social environment are more willing to accept new cultural norms, which in turn will make learning English as an L2 a more successful process. This is consistent with the wider literature, which recognizes social influence as a crucial factor in facilitating cross-cultural adaptation and learning effectiveness.

The cultural dimensions of English language teaching and the need to support them through extra- and co-curricular activities have also been emphasized by empirical research. Indeed, Eccles, Barber, Stone, and Hunt (2003) discovered that English club participants outperformed their non-club mentee partners by 15% highlighting the significance of social learning contexts to academic outcomes. Negi (2024) found that exchange students significantly enhanced their level of English proficiency, as well as their intercultural communication competence and global awareness.

Taken together, these results reveal that social interaction plays an important mediating role in the relationship between contact with a broad range of cultures and successful English learning. In Indonesian society, students at university gain valuable learning experiences through societal and cultural placements beyond the formal curriculum. These environments are crucial for educators and policymakers interested in addressing ESL from holistic, learner-centered perspectives.

- 34 7. The influence of ChatGPT on English language learning performance and its impact on cultural influences mediated by social influence.

More recent findings indicate that using ChatGPT for English language learning not only helps learners develop language competence but also increases their sensitivity to cultural differences. Khzouz, Salaita, Al-Issawi, AlTaher, and Alkhenizan (2024) discovered that students who interacted with ChatGPT to discuss topics related to other cultures learned more about cultural norms and became more culturally sensitive. For instance, students in foreign cultures discussions who used the tool appeared better able to interpret and value culturally diverse social practices and values.

Such results are consistent with Bandura (1977) theory of social learning, which holds that learning is most effective when it occurs in social and observational contexts. It's the interactive and exploratory nature of ChatGPT that enables this type of learning environment, as students are able to witness linguistic subtleties, demonstrate appropriate forms of expression for a given culture, and learn to see the world from another perspective, each of which helps develop intercultural competence.

68 Social support is also key in the process. Namaziandost, Behbahani, and Naserpour (2024) highlighted the important role of peer encouragement and academic community engagement in increasing students' motivation to adopt digital technologies such as ChatGPT. Students who feel supported by peers are also more likely to use learning materials more effectively and in more powerful ways, thereby wielding educational technology to greater effect.

Along similar lines, Perez (2024) also found that cultural awareness is enhanced when working with peers in study groups, such settings offer spaces for dialogue and interaction with content that is culturally different from your own. This is an excellent means for not only improving language abilities but also intercultural competence. Hearing both sides of the story can lead to critical thinking and a more global view for today's interconnected world.

8 In conclusion, these studies underscore the twofold potential of ChatGPT-facilitated English language learning: advancing language fluency and cultural awareness, especially within social support-enabled learning settings. This highlights the need to combine AI-based tools with collaborative learning in assisting the development of linguistically and culturally competent learners in higher education.

## 5. IMPLICATIONS AND CONCLUSION

37 The findings have important implications for policymakers, curriculum designers, and professional development providers in higher education. The resulting model suggests that students' cultural orientation is related to the interplay between social and cultural factors, as well as the impact of English language learning with the use of ChatGPT.

97 It is possible that these findings also have pedagogical implications regarding ESL instruction, in that ESL instruction should not be restricted to grammar- or vocabulary-oriented instruction. Instead, it must focus on culture-bound information, cooperative learning structures, and tech-supported formats. Positive peer learning environments such as study groups and English clubs should be promoted since these environments promote socializing, social pressure, and the cultural open-mindedness of the students. And finally, the adoption of AI-driven tools like ChatGPT, while we're at it, can significantly boost student motivation and keep them active by delivering individualized language learning experiences within the context.

At a policy level, this study signals a need to invest in institutional support for developing digital literacy and cross-cultural relationship building. That might involve investing in training for teachers so they can use AI tools in culturally responsive teaching practices. Institutions should also be responsible for developing learning environments that acknowledge social impact and the influence of social interactions on language acquisition and acculturation.

11 In doing so, the current study fills a gap in the literature by providing a model that combines technology adoption, social dynamics, and cultural integration in the language learning process through social influence. It represents the

implications for Vygotsky (1978) sociocultural learning theory and TAM2 (UTAUT2) applied to AI-mediated education, by connecting university education theories and technology acceptance theories.

There are, however, a range of limitations to bear in mind. Limitation: This study used a cross-sectional design and was limited to university students in Jakarta city; their findings might not be generalizable. Provide longitudinal studies involving multiple institutions in various areas so that the change in cultural attitude and digital learning activity can be reflected. It is also suitable to investigate other mediating factors, such as self-efficacy, engagement, and intercultural competence.

Conclusion: This study underscores the transformative potential of social influence for cultural comprehension and English development, facilitated by AI curation tools such as ChatGPT. The results underline the necessity of inclusive, social-mediated, and culturally sensitive digital pedagogies in the field of EFL. As educators embrace AI-based learning spaces, these need to be grounded in models that recognize the synergy between cultural identity, social interaction, and language development.

These results align with Vygotsky's sociocultural theory, which emphasizes the role of social mediation and peer interaction in learning. The significant impact of social influence supports the idea that learning is culturally situated and socially constructed. Furthermore, the positive association between motivation and ChatGPT usage reflects TAM2's perceived usefulness construct, suggesting that students are more likely to adopt AI when they perceive it as beneficial to their academic success. Unlike studies conducted in Western contexts, this research contributes uniquely to the limited body of literature on AI-supported language education in Southeast Asia, highlighting the interplay between cultural norms and technology acceptance.

**Funding:** This study received no specific financial support.

**Institutional Review Board Statement:** The Ethical Committee of the Faculty of Literature and Language, Universitas Kristen Indonesia, Indonesia has granted approval for this study (Ref. No. 0105/UKIF2.PS/SDM.02.03/2025).

**Transparency:** The authors state that the manuscript is honest, truthful, and transparent, that no key aspects of the investigation have been omitted, and that any differences from the study as planned have been clarified. This study followed all writing ethics.

**Competing Interests:** The authors declare that they have no competing interests.

**Authors' Contributions:** All authors contributed equally to the conception and design of the study. All authors have read and agreed to the published version of the manuscript.

## REFERENCES

- Abd Rahim, E. M., Abd Rahim, M. E., Razawi, N. A., & Mohamed, N. A. (2023). Students' perception on the use of ChatGPT as a language learning tool. *Ideology Journal*, 8(2), 70-78. <https://doi.org/10.24191/ideology.v8i2.456>
- Ahmad, S., Tajul Urus, S., & Syed Mustapha Nazri, S. N. F. (2021). Technology acceptance of financial technology (fintech) for payment services among employed fresh graduates. *Asia-Pacific Management Accounting Journal*, 16(2), 27-58. <https://doi.org/10.24191/apmaj.v16i2-02>
- Ahn, H. Y. (2024). AI-powered e-learning for lifelong learners: Impact on performance and knowledge application. *Sustainability*, 16(20), 9066. <https://doi.org/10.3390/su16209066>
- Ali, J. K. M., Shamsan, M. A. A., Hezam, T. A., & Mohammed, A. A. Q. (2023). Impact of ChatGPT on learning motivation: Teachers and students' voices. *Journal of English Studies in Arabia Felix*, 2(1), 41-49. <https://doi.org/10.56540/jesaf.v2i1.51>
- Alkhatlan, A. A., & Al-Daraiseh, A. A. (2017). An analytical study of the use of social networks for collaborative learning in higher education. *International Journal of Modern Education and Computer Science*, 9(2), 1-13. <https://doi.org/10.5815/ijmecs.2017.02.01>
- Ang, S., Van Dyne, L., Koh, C., Ng, K. Y., Templer, K. J., Tay, C., & Chandrasekar, N. A. (2007). Cultural intelligence: Its measurement and effects on cultural judgment and decision making, cultural adaptation and task performance. *Management and Organization Review*, 3(3), 335-371. <https://doi.org/10.1111/j.1740-8784.2007.00082.x>

- Apoko, T. W., & Waluyo, B. (2025). Social media for English language acquisition in Indonesian higher education: Constructivism and connectivism frameworks. *Social Sciences & Humanities Open*, 11, 101382. <https://doi.org/10.1016/j.ssaho.2025.101382>
- Bandura, A. (1977). *Social learning theory*. Englewood Cliffs, NJ: Prentice Hall.
- Baresh, E. F. (2024). Enhancing writing skills through cultural integration: Exploring the impact of culturally-responsive writing instruction in diverse EFL classrooms. *Global Studies in Education*, 4(1), 47-68.
- Davis, F. D. (1985). A technology acceptance model for empirically testing new end-user information systems: Theory and results. Doctoral Dissertation, Massachusetts Institute of Technology, USA.
- Eccles, J. S., Barber, B. L., Stone, M., & Hunt, J. (2003). Extracurricular activities and adolescent development. *Journal of Social Issues*, 59(4), 865-889. <https://doi.org/10.1046/j.0022-4537.2003.00095.x>
- Fu, P. P., Kennedy, J., Tata, J., Yukl, G., Bond, M. H., Peng, T.-K., . . . Cheosakul, A. (2004). The impact of societal cultural values and individual social beliefs on the perceived effectiveness of managerial influence strategies: A meso approach. *Journal of International Business Studies*, 35(4), 284-305. <https://doi.org/10.1057/palgrave.jibs.8400090>
- Getie, A. S. (2020). Factors affecting the attitudes of students towards learning English as a foreign language. *Cogent Education*, 7(1), 1738184. <https://doi.org/10.1080/2331186X.2020.1738184>
- Govindarajan, R., & Christuraj, G. (2023). Opportunities and challenges of using ChatGPT in the ELT scenario of Utas, Nizwa, Oman. *Journal of Teaching English for Specific and Academic Purposes*, 11(3), 593-605. <https://doi.org/10.22190/JTESAP230529046G>
- Gunther, S. (2021). *The impact of social norms on students' online learning behavior: Insights from two randomized controlled trials*. Paper presented at the Proceedings of the 8th International Conference on Digital Technology in Education (ICDTE 2024), ACM.
- Hair, J. F., Black, W. C., Babin, B. J., & Anderson, R. E. (2010). *Multivariate data analysis* (7th ed.). Upper Saddle River, NJ, USA: Pearson.
- Hair, J. F., Hult, G. T. M., Ringle, C. M., Sarstedt, M., Danks, N. P., & Ray, S. (2021). Evaluation of the structural model. In Partial least squares structural equation modeling (PLS-SEM) using R. In (pp. 115-138). Cham, Switzerland: Springer.
- Hajro, A. (2014). The impact of cultural factors on technology acceptance: A technology acceptance model across Eastern and Western cultures. *International Journal of Information Technology & Decision Making*, 13(4), 757-776.
- Heikkilä, A., Lonka, K., & Nieminen, J. (2017). How prior knowledge influences learning: Insights from educational research. *Learning and Instruction*, 49, 1-10.
- Hidayati, K. H. (2018). Maintaining students' 'Indonesian identity' with a multicultural teaching approach. *ELLITE: Journal of English Language, Literature, and Teaching*, 3(2), 63-68.
- Hofstede, G. (2001). *Culture's consequences: Comparing values, behaviors, institutions and organizations across nations*. Thousand Oaks, CA, USA: Sage.
- Hsieh, G., Chang, Y., & Hsu, C. (2014). Exploring the effects of technology integration on learning outcomes in higher education. *Computers & Education*, 79, 52-60.
- Jamali, U. A. (2023). *Developing creativity via LEGO and AI robotics*. In M. van Wyk (Ed.), *Technology in learning*. London, United Kingdom: IntechOpen.
- Jamshed, M., Manjur Ahmed, A. S. M., Sarfaraj, M., & Warda, W. U. (2024). The impact of ChatGPT on English language learners' writing skills: An assessment of AI feedback on mobile. *International Journal of Interactive Mobile Technologies*, 18(19), 18-36. <https://doi.org/10.3991/ijim.v18i19.50361>
- Juan, W., Qing, S., Yunus, M. M., & Rafiq, K. R. M. (2023). Integrating ChatGPT into English language teaching and learning: Strengths and weaknesses. *International Journal of Academic Research in Business and Social Science*, 13(12), 4055-4068. <https://doi.org/10.6007/IJARBS/v13-i12/20251>
- Kazi, I. H. (2024). Reviewing the role of culture in English language learning: Challenges and opportunities for educators. *Social Sciences & Humanities Open*, 9, 100781. <https://doi.org/10.1016/j.ssaho.2023.100781>

- Khazouz, A., Salaita, O., Al-Issawi, J. M., AlTaher, B. B., & Alkhenizan, H. H. (2024). Exploring ChatGPT practices and user experiences in learning English skills. *Theory and Practice in Language Studies*, 14(12), 3959-3969. <https://doi.org/10.17507/tpls.1412.31>
- Kim, J., Lee, H., & Cho, Y. H. (2022). Learning design to support student-AI collaboration: Perspectives of leading teachers for AI in education. *Education and Information Technologies*, 27(5), 6069-6104. <https://doi.org/10.1007/s10639-021-10831-6>
- Litaay, S. C. H., Manuputty, F. M., Afdhal, A., & Makaruku, N. D. (2025). Local culture-based education in the hidden curriculum: A strategy for fostering tolerance and peace in Maluku secondary schools. *Society*, 13(1), 192-207.
- Maqsood, M., Zahid, A., Asghar, T., Farooqi, S.-u.-H., & Shahbaz, M. (2024). Issues in teaching English in a cultural context. *Migration Letters*, 21(S4), 1020-1027. <https://doi.org/10.59670/ml.v21iS4.7411>
- Mon, A. M., Meer, J. A. E., Edu, C. A. M., Granada, H. J. G., Cortes, M. M., Montejó, J. P., & Abanes, J. P. G. (2025). Impact of social networking sites on enhancing English literacy and speaking skills among selected students. *International Journal of Multidisciplinary: Applied Business and Education Research*, 6(3), 1381-1397.
- Nabavi, R. T., & Bijandi, M. S. (2012). Bandura's social learning theory & social cognitive learning theory. *Theory of Developmental Psychology*, 1(1), 1-24.
- Namaziandost, E., Behbahani, H. K., & Naserpour, A. (2024). Peer support in language learning: Mitigating anxiety, enhancing achievement, cultivating growth mindsets, and increasing enjoyment. *Journal of Applied Learning and Teaching*, 7(2), 296-313. <https://doi.org/10.37074/jalt.2024.7.2.40>
- Negi, B. S. (2024). Promoting cross cultural understanding through English language education: A comparative study in different educational level. *Journal of Language and Linguistics in Society*, 4(2), 27-37. <https://doi.org/10.55529/jlls.42.27.37>
- Oumeddour, S., Baghzou, S., Ounis, S., Derbouch, P., Djafri, L., Golea, T., & Hamadouch, M. (2023). The impact of technology-based instruction on enhancing learners' development of intercultural knowledge in foreign language classrooms. ResearchGate. <https://doi.org/10.13140/RG.2.2.21276.67203>
- Pangesti, M., Khaeriah, A. S., Purwanto, E., Dwi, A., Nur, A., Syafitri, A., . . . Azhari, H. (2024). The influence of social media on the cultural identity of the millennial generation: Indonesian case study. *Pubmedia Social Sciences and Humanities*, 2(1), 1-7. <https://doi.org/10.47134/pssh.v2i1.241>
- Perez, P. L. (2024). The impact of technology-enhanced language learning on bilingual education. *International Journal of Scientific Research and Management*, 12(4), 3340-3350. <https://doi.org/10.18535/ijstrm/v12i04.el05>
- Phuong, H. P. X. (2024). Using ChatGPT in English language learning: A study on I.T. students' attitudes, habits, and perceptions. *International Journal of TESOL & Education*, 4(1), 55-68.
- Prasetya, R. E., & Syarif, A. (2023). ChatGPT as a tool for language development: Investigating its impact on proficiency and self-evaluation accuracy in Indonesian higher education. *Voices of English Language Education Society*, 7(3), 402-415. <https://doi.org/10.29408/veles.v7i3.19303>
- Pratama, R. M. D., & Hastuti, D. P. (2024). The use of artificial intelligence to improve EFL students' writing skill. *English Learning Innovation (englie)*, 5(1), 13-25. <https://doi.org/10.22219/englie.v5i1.30212>
- Sallam, M. (2023). The effects of over-reliance on AI dialogue systems on students' cognitive abilities: A systematic review. *Smart Learning Environments*, 11(1), 1-20.
- Spector, J. M., & Ma, X. (2019). Designing and implementing effective learning environments with emerging technologies. *Educational Technology Research and Development*, 67(3), 437-453.
- Sun, J., Anderson, R. C., Lin, T.-J., Morris, J. A., Miller, B. W., Ma, S., . . . Scott, T. (2022). Children's engagement during collaborative learning and direct instruction through the lens of participant structure. *Contemporary Educational Psychology*, 69, 102061. <https://doi.org/10.1016/j.cedpsych.2022.102061>
- Supriyadi, S. (2020). Cultural representation and intercultural interaction in textbooks of English as an international language. *Journal on English as a Foreign Language*, 10(1), 168-190.
- Syahid, D., Rizki Novia A., Basahil, A., Lestari, A. P., Fatma, & Ningrum, R. L. (2023). The student's perception of using ChatGPT for EFL students. *Jurnal Ilmu Pendidikan Nasional*, 1(3), 143-146.

- Tiawati, R. L., Bidin, A. B., & Baba, S. (2023). How the language competence of international students is culturally oriented when learning Indonesian language. *Studies in Media and Communication*, 11(6), 80-89. <https://doi.org/10.11114/smc.v11i6.6020>
- Utami, S. P. T., Andayani, Winarni, R., & Sumarwati. (2023). Utilization of artificial intelligence technology in an academic writing class: How do Indonesian students perceive? *Contemporary Educational Technology*, 15(4), ep450. <https://doi.org/10.30935/cedtech/13419>
- Venkatesh, V., & Davis, F. D. (2000). A theoretical extension of the technology acceptance model: Four longitudinal field studies. *Management Science*, 46(2), 186-204. <https://doi.org/10.1287/mnsc.46.2.186.11926>
- Vygotsky, L. S. (1978). *Mind in society: The development of higher psychological processes* (M. Cole, V. John-Steiner, S. Scribner, & E. Souberman, Eds. & Trans.). Cambridge, MA: Harvard University Press.
- Wallace, M. P., & Leong, E. I. L. (2020). Exploring language learning motivation among primary EFL learners. *Journal of Language Teaching and Research*, 11(2), 221-230. <https://doi.org/10.17507/jltr.1102.10>
- Wang, Y. (2025). A study on the efficacy of ChatGPT-4 in enhancing students' English communication skills. *Sage Open*, 15(1), 21582440241310644. <https://doi.org/10.1177/21582440241310644>
- Zhao, W., Osman, M. N., Omar, S. Z., & Yaakup, H. S. (2022). Mediating role of cultural identity in the relationship between social media use intensity and social media use purpose among Chinese international students in Malaysia. *Studies in Media and Communication*, 10(2), 201-217. <https://doi.org/10.11114/smc.v10i2.5698>
- Zou, X., Su, P., Li, L., & Fu, P. (2023). AI-generated content tools and students' critical thinking: Insights from a Chinese university. *IFLA Journal*, 50(2), 228-241. <https://doi.org/10.1177/03400352231214963>

*Views and opinions expressed in this article are the views and opinions of the author(s), International Journal of Education and Practice shall not be responsible or answerable for any loss, damage or liability etc. caused in relation to/arising out of the use of the content.*