

Application of an inductive sensor system for identifying ripeness and forecasting harvest time of oil palm

by Rismen Sinambela

Submission date: 03-Nov-2023 03:39PM (UTC+0700)

Submission ID: 2216133321

File name: Jurnal_Internasional_Rismen.pdf (1.49M)

Word count: 4933

Character count: 26270



Application of an inductive sensor system for identifying ripeness and forecasting harvest time of oil palm



Rismen Sinambela^a, Tineke Mandang^{b,*}, I. Dewa Made Subrata^b, Wawan Hermawan^b

^a Graduate School of Agricultural Engineering Science, Faculty of Agricultural Engineering and Technology, IPB University, Bogor, 16680, Indonesia

^b Department of Mechanical and Biosystem Engineering, Faculty of Agricultural Engineering and Technology, IPB University, Bogor, 16680, Indonesia

ARTICLE INFO

Keywords:

Discriminant analysis
Inductive sensor
Oil palm ripeness
Polynomial regression

ABSTRACT

Ripeness estimation of oil palm fresh fruit bunches is a crucial component in the management of oil palm harvesting, as it will lead to profitability and marketability of the product. The purpose of this study is to develop an oil palm maturity detection device that not only able to identify oil palm maturity, but also predict harvest time. In this work, the resonant frequency data were collected using an inductive sensor from a total of 600 fruits at various ages of ripeness. Intelligent algorithms are embedded into the system to recognize the oil palm ripeness, i.e., discriminant analysis for identifying ripeness and polynomial regression for forecasting harvest time. In oil palm plantations, we prepared 55 fresh fruit bunches to identify their ripeness and forecast harvest time. Based on the field test performance, the inductive sensor system can determine the oil palm ripeness with an accuracy of 100 % and forecast the harvest time with RMSE of 13.45. Therefore, the proposed system has the potential to be implemented in the evaluation of harvesting oil palm due to its various advantages, i.e., being accurate, rapid and non-invasive.

1. Introduction

The total oil palm cultivated in Indonesia increased by 1.25%–14 million hectares in 2017 (Ministry of Agriculture of the Republic of Indonesia, 2018). Indonesia produces an average of 2.69 tons of oil palm fresh fruit bunches (FFB) per hectare. The oil palm companies in Indonesia significantly contribute to gross domestic products, around 3.5 %. Currently, Indonesia produces more than 45 % of the world's oil palm production and has become a leading player in the world oil palm trade since the 1950s (Makky and Soni, 2014). A massive deal of research on oil palm has been carried out by the universities, research institutes and oil palm industries to improve oil quality (Dradjat, 2012; Wisena et al., 2014). In order to produce high-quality oil, harvesting process is crucial, since it relates to the oil content level. The harvesting process must be conducted when the fruit is at optimal ripeness (about 151–180 days after anthesis) to get high oil content (Saragih, 2019). However, on-field, the oil palm company is dealing with thousands of palm trees with different stages of maturity. The harvesting schedule has been arranged in detail to identify harvest time, but this is not good enough to solve this problem, as each tree produces FFB with a different maturity. Besides, the conventional method still uses the number or percentage of detached fruits per bunch as a measure of the FFB ripeness. This method is a time-consuming, labor-intensive process and is

prone to human error (Makky and Soni, 2014; Saeed et al., 2012). Therefore, the process of harvesting oil palm requires a technological breakthrough that is reliable, non-invasive, accurate and rapid to evaluate the FFB maturity.

Various advanced technologies have been involved in detecting oil maturity, among others based on near-infrared spectroscopy (Makky and Soni, 2014; Saeed et al., 2012), image processing (Alfatni et al., 2014), flavonoid and anthocyanin content (Hazir et al., 2012) and inductive sensor (Misron et al., 2017). Recently, the reliable promising technology in detecting oil palm maturity is based on the inductive sensor. This technology was first proposed by Harun et al. (2013), where they analyze the resonance frequency of the palm fruit. They stated that the riper the oil palm fruit, the higher its resonant frequency. Furthermore, inductive sensors have been used to solve various issues in the agriculture field such as conductivity of topsoil estimation (Ambruš et al., 2015), dairy cow health monitoring (Minnaert et al., 2018) and soil water content prediction (Kachanoski et al., 1988). Therefore, this study adopted this technology in the development of an oil palm ripeness detection device with several modifications such as frequency selection, electrical circuit and inductive sensor design.

However, based on the state of the art, overall the oil palm maturity detection devices have only one single capability, i.e., identifying the

* Corresponding author.

E-mail address: tineke_mandang_2003@yahoo.com (T. Mandang).

<https://doi.org/10.1016/j.scienta.2020.109231>

Received 29 October 2019; Received in revised form 22 January 2020; Accepted 23 January 2020
0304-4238/ © 2020 Elsevier B.V. All rights reserved.

oil palm ripeness. In this study, we propose a device that is not only able to identify the oil palm ripeness, but also predict the harvest time. Clearly, there is a scope for improvement. The knowledge on harvest time is vital, because if the FFB detected is unripe, then when to harvest it. Through the proposed device, oil palm harvest management will run more effectively and efficiently.

For the fruitfulness of this system, an intelligent algorithm such as artificial neural network, discriminant analysis, deep learning or support vector machine (Faricha et al., 2018; Kuo and Faricha, 2016; Nanda et al., 2018a; Nazari, 2012; Stowell et al., 2019) is needed to install the device capabilities in identifying ripeness and forecasting harvest time of oil palm. In this study, because the proposed device is a portable hand-held device, the primary consideration in algorithm selection is an accurate and simple formula to provide rapid decision-making. Various involved algorithms in detecting oil palm ripeness are multiple linear regression (Makky and Soni, 2014), discriminant analysis (Saeed et al., 2012), stochastic gradient boosting trees (Hazir et al., 2012), k-nearest neighbor (Alfatni et al., 2014), artificial neural network (Cherie, 2015) and partial least square (Iqbal et al., 2015). Based on the benchmarking process, the algorithm embedded in this system is discriminant analysis for identifying ripeness and polynomial regression for forecasting harvest time. Both algorithms have the potential to analyze nonlinear and nonstationary signal series generated by the inductive sensor. Based on the above-mentioned considerations, the objective of this study is to develop a device capable of identifying ripeness and forecasting harvest time of oil palm.

2. Materials and method

2.1. Data collection

The oil palm FFBs were harvested from 10 to 25-year-old trees from January-February, 2019 at Cikabayan Oil Palm Plantation (IPB University, Bogor, Indonesia) and Cikasingka PTPN VIII Oil Palm Plantation in Bogor, Indonesia. The samples used were tenera varieties (*Elaeis guineensis* Jacq. var. tenera), which were harvested at various ages of ripeness. Based on the ripeness protocol in the oil palm plantation, ripe oil palm is harvested at 151–180 days after anthesis, while unripe oil palm is harvested at 0–150 days after anthesis. In this study, a total of 600 oil palm fruits were harvested and grouped into two classes, i.e., ripe (100 fruits) and unripe (500 fruits). The FFB's samples were classified by professional labors based on the oil palm database library in each plantation. These entire fruit samples were used for the development of signal processing in recognizing the age of oil palm ripeness.

2.2. Inductive sensor system

The proposed inductive sensor system is made of two stainless steel plates that are curved with a dimension of $10 \times 1 \times 0.01$ cm. This sensor is connected to the electronic circuit board inside the sensing panel to convert a signal into an equivalent electrical voltage. The filtered signal is input in an ATmega328 P microcontroller (Arduino Uno, Ivrea, Italy), which manages the whole device and runs a specially designed processing algorithm (Fig. 2).

The basic principle of this system is that the inductive sensor is pasted on the oil palm FFB to measure its resonant frequency. Thus, the embedded algorithm outputs a signal related to the age of oil palm ripeness. The result of the ripeness evaluation by the inductive sensor system is connected and displayed on a mobile phone using Bluetooth Terminal HC-05 (MightyIT, Gujarat, India). Also, this system is powered by a rechargeable battery (6V) to supply power requirements to the system and is equipped with an adjustable stick (maximum length of 9 m) to reach oil palm FFB. The overall components of the inductive sensor housing are shown in Fig. 1.

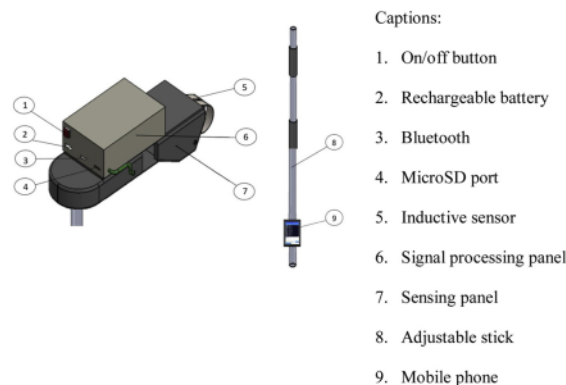

Fig. 1. Inductive sensor system.

2.3. Signal processing overview

2.3.1. Resonant frequency

The electrical diagram of the proposed inductive sensor system is shown in Fig. 3. In RLC circuit representation, the main parameter to identify ripeness and estimate oil palm harvest time is the resonant frequency. This is a parameter generated from the application of the inductive sensor. In theory, resonant frequency implies a unique frequency determined by the values of the capacitance and inductance. The resonant frequency can be determined using Eq. (1), where, f_r is resonant frequency (Hz), L is inductance (H) and C is capacitance (F).

$$f_r = \frac{1}{2\pi\sqrt{LC}} \quad (1)$$

The frequency change is greatly influenced by its capacitance value, because it is closely related to the dielectric properties of oil palm. So that each particular age of oil palm ripeness has a distinctive resonant frequency value. In this study, for an inductive sensor plate, its capacitance value is calculated using Eq. (2). Where K is constant dielectric, A is the surface area of the plater (m^2) and D is the distance between the plates (m).

$$C = \frac{KA}{4\pi D} \quad (2)$$

2.3.2. Identifying ripeness

Discriminant analysis is applied to identify oil palm FFB ripeness. This technique is used for the classification of objects into groups, i.e., ripe or unripe oil palm FFB based on resonant frequency value. Discriminant analysis is a predictive technique based on multivariate statistical learning. This technique may be used in numerous applications, for example, in ecology (Liu et al., 2018; Nanda et al., 2018b) and engineering field (Yang et al., 2018). According to Kočíšová and Mišanková (2014), the main task of discriminant analysis is to find the optimal attributing rules that will minimize the likelihood of erroneous classification elements.

After the training process identifies the characteristics of ripe and unripe oil palm, the discriminant analysis produces a formula containing the attributes of each class. This basic model of discriminant analysis is given in Eq. (3), where d is a discriminant function, b_0 is intercept, b_i is coefficient, x_i is variable (in this study is resonant frequency) and $i = 1, \dots, n$. In this study, discriminant analysis was performed in XLSTAT version 2014.5.03 (Adinsoft) with easy built-in package. Furthermore, the discriminant analysis model is embedded in the oil palm ripeness detection to provide a decision.

$$d = b_0 + b_1x_1 + b_2x_2 + b_3x_3 + \dots + b_nx_n = b_0 + \sum_{i=1}^n b_{(i)}x_{(i)} \quad (3)$$

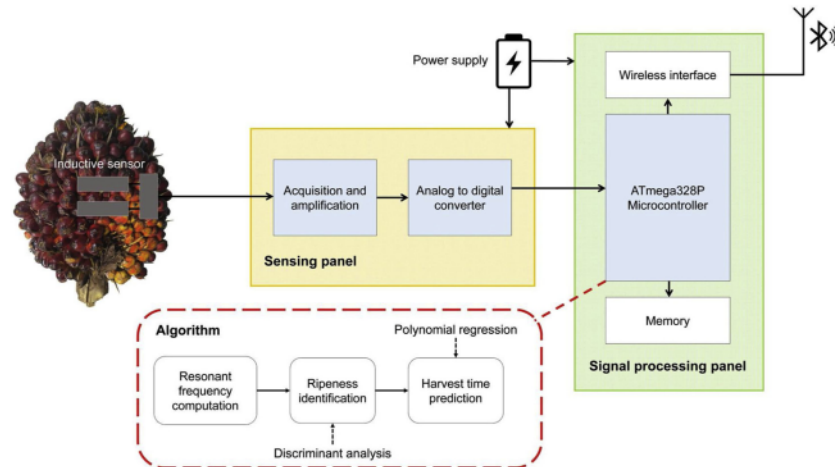

Fig. 2. Inductive sensor system architecture.

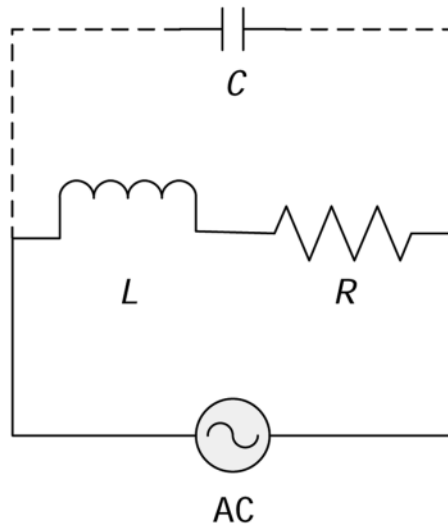

Fig. 3. RLC circuit in an inductive sensor system.

2.3.3. Forecasting harvest time

The proposed device is equipped with a feature to forecast the harvest time of oil palm. This feature will work to estimate the harvest time when the detected oil palm FFB is still in an unripe condition. This is a new feature that is not found in various existing oil palm ripeness detection devices. In order to forecast a harvest time, a polynomial regression with a degree ($k = 2$) was implemented to examine the relationship between resonant frequency (f_r) and age of ripeness (A_r). The basic model of polynomial regression is as follows:

$$A_r = b_0 + b_1 f_r^2 + b_2 f_r \quad (4)$$

After the age of ripeness is known, the harvest time (H_t) can be determined by calculating the deviation between the maximum age of ripe oil palm (180 days) and the measured oil palm ripeness:

$$H_t = 180 - A_r \quad (5)$$

2.4. Performance evaluation

In this study, the type of data was divided into two sets (training and testing) at a ratio of 8:2 using holdout validation. From a total of 600 data samples, there were 480 data for training set and 120 data for testing set. The model performance was evaluated by comparing the prediction results and measured values. The accuracy (A_c) of the first model, i.e. discriminant analysis for identifying the oil palm ripeness, is calculated by using Eq. (6). This is the probability that the classification tests yield the correct determination. Good performance is proven by high accuracy value, where, C_c is correct classification samples and N is total samples. The second model, polynomial regression to estimate the age of oil palm ripeness, is evaluated using root mean square error (RMSE) and coefficient of determination (R^2). A good model should have a low RMSE and high R^2 (Nanda et al., 2019), where y_p is the prediction value, y_i is the actual value and y_m is the average predicted value.

$$A_c = \frac{C_c}{N} \times 100(\%) \quad (6)$$

$$RMSE = \sqrt{\frac{1}{N} \sum_{i=1}^N (y_p - y_i)^2} \quad (7)$$

$$R^2 = \left(\frac{\sum_{i=1}^N (y_p - y_i)^2}{\sum_{i=1}^N (y_p - y_m)^2} \right) \quad (8)$$

In addition, in order to determine the real performance of our system, we performed a blind field test-driven by the third-party evaluator at Cikabayan and Cikasungka Oil Palm Plantation. At this stage, the proposed device was tested to identify ripeness and forecast harvest time. A total of 55 FFBs in various ages of ripeness were used in this blind test. The inductive sensor system was touched at one point around the central area of FFB to make a decision on its maturity status. As a correctness reference, the oil palm database libraries in each plantation supervised by professional labors, were used to validate the measurement results of the inductive sensor system.

3. Results

3.1. Inductive sensor characteristics

The characteristics of the inductive sensor were evaluated. Based on

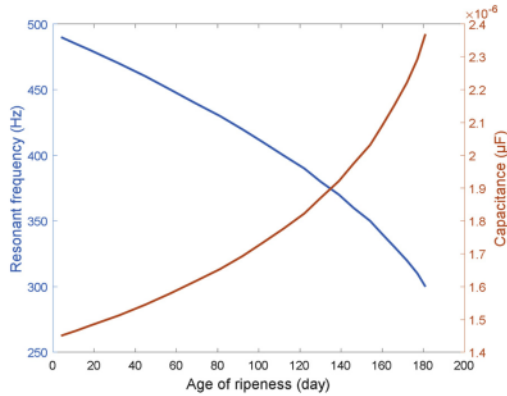

Fig. 4. Inductive sensor characteristics in various ages of ripeness.

the analysis, the riper the fruit is, the lower its resonance frequency and the higher its capacitance (Fig. 4). These results confirm that the resonant frequency and capacitance are inversely proportional in accordance with Eq. (1). However, in contrast to the research conducted by Misron et al. (2017), they explained that the more mature the fruit, the higher its resonance and the lower its capacitance. This difference is caused by each instrumentation having specific electrical characteristics that can lead to distinct output conversion results. For example, this study was performed in low frequency (270–500 Hz), while the previous research conducted by Misron et al. (2017) was applied in high frequency (8.5–9.8 MHz). Nevertheless, the most critical aspect in the development of oil palm ripeness detection is the close relationship between signal characteristics against the fruit ripeness level.

3.2. Proposed algorithm

3.2.1. Identifying ripeness

The discriminant analysis was developed to identify the oil palm FFB ripeness. Fig. 5 shows the training process of discriminant analysis between two principal components (PC₁ and PC₂) to recognize the ripe and unripe FFB. As can be seen, each class has a centroid to create optimal boundaries. Visually, the two classes can be separated at the expense of overlapping data. Based on the analysis, the models representing the overall characteristics of each class are defined in Eq. (9) for ripe and Eq. (10) for unripe. These are valuable property,

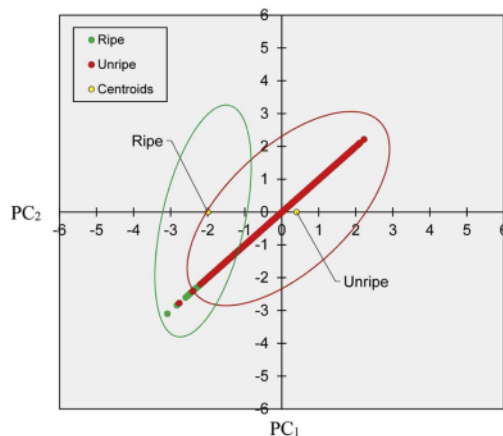

Fig. 5. Discriminant analysis simulation in classifying ripe and unripe of oil palm.

Table 1

Confusion matrix for the cross-validation results.

From \ to	Ripe	Unripe	Total	Accuracy (%)
Ripe	15	1	16	93.75 %
Unripe	8	96	104	92.31 %
Total	23	97	120	92.50 %

successfully issued by discriminant analysis. The main rule in this model is that we classify the class (i.e., ripe or unripe) corresponding to the model that gives the greatest value. For example, by inputting the f_r value, if ripe > unripe, then the observation is grouped into ripe. Moreover, these models can be implemented for the inductive sensor system for identifying a new observation. To test the model performance, we apply the cross-validation technique using 120 testing data sets. Based on the analysis, the discriminant analysis model achieves 92.50 % of accuracy (Table 1). This indicates that the model is applicable to be embedded in the system in providing fast and accurate decisions.

$$\text{Ripe} = -39.3284 + 0.1903f_r \tag{9}$$

$$\text{Unripe} = -22.6083 + 0.1388f_r \tag{10}$$

3.2.2. Forecasting harvest time

The core step to predict harvest time is tracing the age of ripeness first. The polynomial regression is applied to build a model that can estimate the age of ripeness. First, the entire training data sets are averaged and grouped into six major ripeness ages, i.e., 30, 60, 90, 120, 150 and 180 days after anthesis. From the various methods used, this method produced the highest R² (0.763). Fig. 6 shows the relationship between resonant frequency and age of ripeness. Visually, the lower the resonant frequency, the riper the oil palm FFB. Thus, the age of ripeness can be predicted using a mathematical model of A_r , generated by polynomial regression. To test the model performance, we calculate the error prediction of testing data set between the actual and estimated value using RMSE. Based on the analysis, the polynomial regression achieved an RMSE of 21.37 for forecasting the age of ripeness.

3.3. Blind field test

The successfully-developed model is then embedded and integrated into the inductive sensor system. This device was tested blindly in the field to obtain the circumstances of its performance. Fig. 7 shows the user evaluating each FFB. The measurement results are analyzed in the

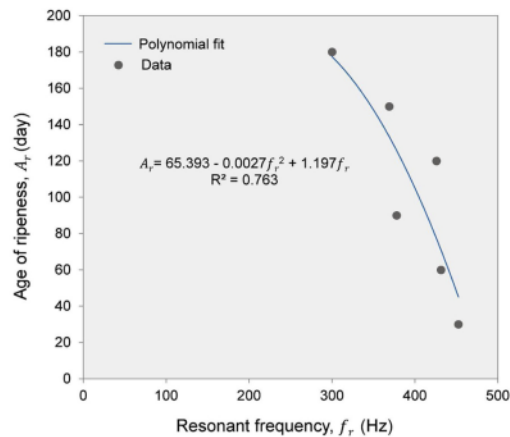

Fig. 6. Resonant frequency value at various age of oil palm ripeness.

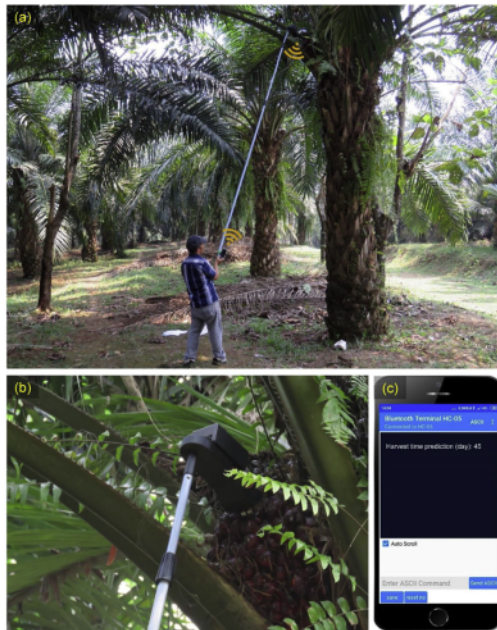

Fig. 7. (a) The user attaches the inductive sensor to the FFB; (b) the system analyzes the resonant frequency (c) the FFB evaluation results on the mobile phone user interface.

signal processing panel and the results are displayed on a mobile phone using Bluetooth technology. In the user interface design, we have a simplified measurement result that is easily understood by the human domain. If the computational result displays a minus value, then FFB is ripe. Vice versa, if the computational result displays a positive value, then FFB is unripe; and this positive value also shows the estimated harvest. For example, if the FFB measurement result is 45, then this FFB is grouped as unripe and it can be harvested 45 days later.

A total of 55 FFBs were prepared to test the inductive sensor system in identifying oil palm ripeness and forecasting harvest time. Based on the analysis, the proposed system is able to correctly identify the entire ripe and unripe status of oil palm FFB (Fig. 8). Therefore, the accuracy of this system to determine oil palm ripeness is 100 %. Furthermore,

		Actual value	
		Ripe	Unripe
Predicted value	Ripe	12	0
	Unripe	0	43

Fig. 8. Confusion matrix of inductive sensor system in identifying oil palm ripeness.

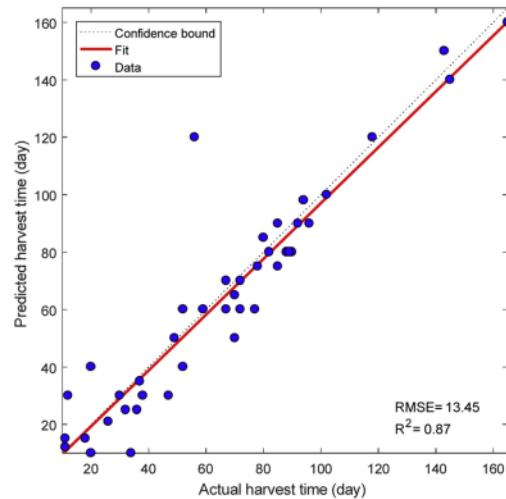

Fig. 9. The inductive sensor system performance in forecasting harvest time.

there were 43 FFBs identified as unripe, and this device will forecast the harvest time automatically. This study confirms that the inductive sensor system can predict harvest time with 13.45 of RMSE (Fig. 9). The overall results showed acceptable performance both in model simulation and blind field test. We are optimistic that this new feature installed in this device is required for optimal precision in the oil palm harvesting.

4. Discussion

Oil palm ripeness detection is crucial decision-making information in harvesting, because this will lead to company profits and marketability of the product. If oil palm is harvested in overripe conditions, it has high free fatty acids, which contribute to lower oil content (Junkwon et al., 2009). Conversely, if oil palm is harvested in unripe conditions, then the oil content is still low. Therefore, oil palm must be collected at the right time, which is 151–180 days after anthesis. As discussed in the introduction section, the conventional harvesting method involves manual detection by counting a number of loosened fruits per bunch (Makky and Saad, 2014). Such method is subjective and tends to be erroneous. Also, it is a time-consuming and labor-intensive process, resulting in bias and risk of human error. Therefore, there is an opportunity for the development of a reliable, rapid and accurate oil palm ripeness detection device.

This study developed a simple, non-invasive, inductive sensor system for identifying ripeness and forecasting harvest time in oil palm FFB. The inductive sensor system in-conjunction with discriminant analysis and polynomial regression could determine the oil palm ripeness with a 100 % accuracy and forecast the harvest time with RMSE of 13.45, respectively. This system enhances various existing oil palm ripeness detection devices through new features, i.e., the ability to forecast harvest time.

The performance of the proposed system is comparable with various sophisticated oil palm ripeness detection technologies. The various technologies and their performances are summarized as follows: (1) based on visible-near infrared sensor, Saeed et al. (2012) can detect oil palm maturity with 85 % of accuracy; (2) based on machine vision system, Abdullah et al. (2001) reported their triumph in detecting oil palm maturity up to 100 % of accuracy; (3) based on image processing analysis, Alfatni et al. (2014) can identify oil palm ripeness with an accuracy of 95 %. Also, there were some attractive studies regarding the identification of oil palm ripeness, but its performance was not

mentioned, including near-infrared spectroscopy (Makky and Aliteh, 2014), image vision (Cherie, 2015) and inductive sensor (Aliteh et al., 2018; Harun et al., 2013; Misron et al., 2017, 2014). Also, these sophisticated devices have only shown success in simulating oil palm ripeness mathematical models on the laboratory scale, wherein their feasibility in the field is still questionable. In contrast this study, we have proven that the inductive sensor system works appropriately, not only in mathematical model simulation, but also in-field testing.

In this study, the inductive sensor system can prove several benefits, namely (i) rapid detection, computation process is less than 1 s, (ii) ergonomically, the device is equipped with an adjusted stick (9 m of height) to harvest FFB and the measurement result is displayed via a mobile phone using Bluetooth technology, (iii) forecasting harvest time, if FFB is still unripe, it can predict harvest time, (iv) accuracy, the proposed device is able to identify the oil palm ripeness with an accuracy of 100 % and forecast the harvest time with RMSE of 13.45. Ultimately, this inductive sensor system has promising potential to lead to the effective and efficient management of oil palm harvesting.

5. Conclusion

This study developed and evaluated the implementation of an inductive sensor system for oil palm ripeness identification. The resonant frequency value derived from the inductive sensor was used for the development of the intelligent algorithms, i.e., discriminant analysis for identifying ripeness and polynomial regression for forecasting harvest time. Based on the performance in the blind field test, the proposed system can determine the oil palm ripeness with a 100 % accuracy and forecast the harvest time with RMSE of 13.45. These results indicate that the inductive sensor system has the potential to be applied in evaluating oil palm harvesting due to its various advantages, i.e., being accurate, rapid and non-invasive.

22 CRediT authorship contribution statement

Rismen Sinambela: Investigation, Data curation, Methodology, Conceptualization, Writing - original draft, Software, Validation, Visualization. **Tineke Mandang:** Supervision, Methodology, Formal analysis. **I. Dewa Made Subrata:** Supervision, Writing - review & editing, Conceptualization. **Wawan Hermawan:** Supervision, Writing - review & editing, Conceptualization.

Declaration of Competing Interest

The authors declare that they have no known competing financial interests or personal relationships that could have appeared to influence the work reported in this paper.

Acknowledgment

The authors would like to acknowledge the Indonesia Endowment Fund for Education (LPDP) and The Ministry of Research, Technology and Higher Education of the Republic of Indonesia for providing financial support (project no. PRJ-6173 /LPDP.3/2016).

References

Abdullah, M., Guan, L., Azemi, B.M., 2001. Stepwise discriminant analysis for colour grading of oil palm using machine vision system. *Food Bio. Proc.* 79, 223–231.
 Alfatni, M., Shariff, A., Abdullah, M., Marhaban, M., Shafie, S., Bamiruddin, M., Saeed, O., 2014. Oil palm fresh fruit bunch ripeness classification based on rule-based expert system of ROI image processing technique results. In: *IOP Conference Series: Earth*

and Environmental Science. IOP Publishing. pp. 012018.
 Aliteh, N., Misron, N., Aris, I., Mohd Sidek, R., Tashiro, K., Wakiwaka, H., 2018. Triple flat-type inductive-based oil palm fruit maturity sensor. *Sensors* 18, 2496.
 Ambruš, D., Špikić, D., Vasić, D., Bilas, V., 2017. Sensitivity Profile of Compact Inductive Sensor for Apparent Electrical Conductivity of Topsoil, 2017 IEEE SENSORS. IEEE, pp. 1–3.
 Cherie, D., 2015. Pengembangan sistem deteksi kematangan tandan buah segar (tbs) sawit berdasarkan karakteristik optik, Agricultural Engineering Science. IPB University, Bogor.
 Drajat, B., 2012. Structure, roles, challenges and opportunities of the oil palm industry in Indonesia: the significance of oil palm smallholders. *Oil Palm Bull.* 64, 1–2.
 Faricha, A., Suwito, S., Rivai, M., Nanda, M., Purwanto, D., 2018. Design of electronic nose system using gas chromatography principle and surface acoustic wave sensor. *TELKOMNIKA* 16, 1457–1467.
 Harun, N., Misron, N., Sidek, R., Aris, I., Ahmad, D., Wakiwaka, H., Tashiro, K., 2013. Investigations on a novel inductive concept frequency technique for the grading of oil palm fresh fruit bunches. *Sensors* 13, 2254–2266.
 Hazir, M.H.M., Shariff, A.R.M., Amiruddin, M.D., 2012. Determination of oil palm fresh fruit bunch ripeness—based on flavonoids and anthocyanin content. *Ind. Crops Prod.* 36, 466–475.
 Iqbal, Z., Herodian, S., Widodo, S., 2015. Pendugaan kadar air dan total karoten tandan buah segar (tbs) kelapa sawit menggunakan nir spektroskopi. *J. Ket. Pert.* 2.
 Junkwon, P., Takigawa, T., Okamoto, H., Hasegawa, H., Koike, M., Sakai, K., Siruntawinetti, J., Chaeychomsri, W., Vanavichit, A., Tittinuchanon, P., 2009. Hyperspectral imaging for nondestructive determination of internal qualities for oil palm (Elaeis guineensis Jacq. Var. tenera). *Agric. Inf. Res.* 18, 130–141.
 Kachanoski, R., WESENBECK, I.V., Gregorich, E., 1988. Estimating spatial variations of soil water content using noncontacting electromagnetic inductive methods. *Can. J. Soil Sci.* 68, 715–722.
 Kočiřová, K., Miřanková, M., 2014. Discriminant analysis as a tool for forecasting company's financial health. *Proc. Behav. Sci.* 110, 1148–1157.
 Kuo, H.-F., Faricha, A., 2016. Artificial neural network for diffraction based overlay measurement. *IEEE Access* 4, 7479–7486.
 Liu, J., Xie, H., Zha, B., Ding, W., Luo, J., Hu, C., 2018. Detection of genetically modified sugarcane by using terahertz spectroscopy and chemometrics. *J. App. Spec.* 85, 119–125.
 Makky, M., Soni, P., 2014. In situ quality assessment of intact oil palm fresh fruit bunches using rapid portable non-contact and non-destructive approach. *J. Food Eng.* 120, 248–259.
 Ministry of Agriculture of the Republic of Indonesia, 2018. Agricultural Statistics. Center for Agricultural Data and Information System. Accessed on 20 Augustus 2019. Available on: <http://epublikasi.setjen.pertanian.go.id/download/file/390-statistik-pertanian-2017>.
 Minnaert, B., Thoen, B., Plets, D., Joseph, W., Stevens, N., 2018. Wireless energy transfer by means of inductive coupling for dairy cow health monitoring. *Comput. Electron. Agric.* 152, 101–108.
 Misron, N., Harun, N., Lee, Y., Sidek, R., Aris, I., Wakiwaka, H., Tashiro, K., 2014. Improvement in sensitivity of an inductive oil palm fruit sensor. *Sensors* 14, 2431–2448.
 Misron, N., Aliteh, N., Harun, N., Tashiro, K., Sato, T., Wakiwaka, H., 2017. Relative estimation of water content for flat-type inductive-based oil palm fruit maturity sensor. *Sensors* 17, 52.
 Nanda, M.A., Seminar, K.B., Nandika, D., Maddu, A., 2018a. A comparison study of kernel functions in the support vector machine and its application for termite detection. *Information* 9, 5.
 Nanda, M.A., Seminar, K.B., Nandika, D., Maddu, A., 2018b. Discriminant analysis as a tool for detecting the acoustic signals of termites *Coptotermes curvignathus* (Isoptera: rhinotermitidae). *Int. J. Tech.* 9, 840–851.
 Nanda, M.A., Seminar, K.B., Nandika, D., Maddu, A., 2019. Development of termite detection system based on acoustic and temperature signals. *Measurement* 147, 106902.
 Nazari, A., 2019. Prediction water absorption resistance of lightweight geopolymers by artificial neural networks. *Neural Comput. App.* 31, 759–766.
 Saeed, O.M.B., Sankaran, S., Shariff, A.R.M., Shafri, H.Z.M., Ehsani, R., Alfatni, M.S., Hazir, M.H.M., 2012. Classification of oil palm fresh fruit bunches based on their maturity using portable four-band sensor system. *Comput. Electron. Agric.* 82, 55–60.
 Saragih, D.P.P., 2019. Prediksi kematangan tandan kelapa sawit dengan metode edge detection dan pewarnaan rgb (the ripeness prediction of oil palm bunches with edge detection and RGB staining method). In: *Proceedings of Seminar Nasional Perteta 2018*. Yogyakarta, Indonesia.
 Stowell, D., Wood, M.D., Pamula, H., Stylianou, Y., Glotin, H., 2019. Automatic acoustic detection of birds through deep learning: the first bird audio detection challenge. *Meth. Ecol. Evol.* 10, 368–380.
 Wisena, B.A., Daryanto, A., Arifin, B., Oktaviani, R., 2014. Sustainable development strategy and the competitiveness of Indonesian palm oil industry. *Int. J. Managerial Stud. Res.* 2, 102–115.
 Zhang, Z., Zhang, Y., Kos, A., Umek, A., 2018. Strain gage sensor based golfer identification using machine learning algorithms. *Proc. Comp. Sci.* 129, 135–140.

Application of an inductive sensor system for identifying ripeness and forecasting harvest time of oil palm

ORIGINALITY REPORT

18%

SIMILARITY INDEX

11%

INTERNET SOURCES

15%

PUBLICATIONS

5%

STUDENT PAPERS

PRIMARY SOURCES

- 1 Inna Novianty, Ringga Gilang Baskoro, Muhammad Iqbal Nurulhaq, Muhammad Achirul Nanda. "Empirical mode decomposition of near-infrared spectroscopy signals for predicting oil content in palm fruits", Information Processing in Agriculture, 2022
Publication 2%
- 2 www.semanticscholar.org
Internet Source 2%
- 3 Muhammad Achirul Nanda, Kudang Boro Seminar, Dodi Nandika, Akhiruddin Maddu. "Development of termite detection system based on acoustic and temperature signals", Measurement, 2019
Publication 2%
- 4 Osama Mohammed Ben Saeed, Sindhuja Sankaran, Abdul Rashid Mohamed Shariff, Helmi Zulhaidi Mohd Shafri et al. "Classification of oil palm fresh fruit bunches

based on their maturity using portable four-band sensor system", Computers and Electronics in Agriculture, 2012

Publication

5	www.iue.tuwien.ac.at Internet Source	1 %
6	journal.ipb.ac.id Internet Source	1 %
7	vdocuments.mx Internet Source	1 %
8	www.docstoc.com Internet Source	1 %
9	Muhammad Makky, Peeyush Soni. "In situ quality assessment of intact oil palm fresh fruit bunches using rapid portable non-contact and non-destructive approach", Journal of Food Engineering, 2014 Publication	1 %
10	Mohd Hafiz Mohd Hazir, Abdul Rashid Mohamed Shariff, Mohd Din Amiruddin. "Determination of oil palm fresh fruit bunch ripeness—Based on flavonoids and anthocyanin content", Industrial Crops and Products, 2012 Publication	1 %
11	www.mdpi.com Internet Source	1 %

12

Fadilah, Norasyikin, Junita Mohamad-Saleh, Zaini Abdul Halim, Haidi Ibrahim, and Syed Syed Ali. "Intelligent Color Vision System for Ripeness Classification of Oil Palm Fresh Fruit Bunch", *Sensors*, 2012.

Publication

<1 %

13

Muhammad Achirul Nanda, Kudang Boro Seminar, Akhiruddin Maddu, Dodi Nandika. "Acoustic and temperature signals generated by subterranean termite infestation: its characteristics and implementations", *All Life*, 2023

Publication

<1 %

14

Shahrol Mohamaddan, Magdalene Andrew-Munot, Shirley Johnathan Tanjong, Siti Zawiah Md Dawal, Keith Case, Akihiko Hanafusa. "Investigation of the Usage of Oil Palm Harvesting Tools on Work Related Musculoskeletal Disorders of Lower Limb", *2021 IEEE 3rd Eurasia Conference on Biomedical Engineering, Healthcare and Sustainability (ECBIOS)*, 2021

Publication

<1 %

15

www.inderscience.com

Internet Source

<1 %

16

sci-hub.se

Internet Source

<1 %

17	Submitted to Universiti Putra Malaysia Student Paper	<1 %
18	openaccess.artvin.edu.tr Internet Source	<1 %
19	"VIII Latin American Conference on Biomedical Engineering and XLII National Conference on Biomedical Engineering", Springer Science and Business Media LLC, 2020 Publication	<1 %
20	encyclopedia.pub Internet Source	<1 %
21	Asma-Qamaliah Abdul-Hamid, Mohd Helmi Ali, Lokhman Hakim Osman, Ming-Lang Tseng. "The drivers of industry 4.0 in a circular economy: The palm oil industry in Malaysia", Journal of Cleaner Production, 2021 Publication	<1 %
22	Wuliyasu Bai, Long Zhang, Shengfang Lu, Jingzheng Ren, Zhiqiao Zhou. "Sustainable energy transition in Southeast Asia: Energy status analysis, comprehensive evaluation and influential factor identification", Energy, 2023 Publication	<1 %

23

Internet Source

<1 %

24

A Ruswanto, A H Ramelan, D Praseptiangga, I B B Partha. "The study of carotene content and iodine value of oil from different ripening levels and storage duration of palm fresh fruit bunches", IOP Conference Series: Earth and Environmental Science, 2021

Publication

<1 %

25

cyberleninka.org

Internet Source

<1 %

26

dokumen.pub

Internet Source

<1 %

27

Taparugssanagorn, Attaphongse, Siwaruk Siwamogsatham, and Carlos Pomalaza-Ráez. "A non-destructive oil palm ripeness recognition system using relative entropy", Computers and Electronics in Agriculture, 2015.

Publication

<1 %

28

download.atlantispress.com

Internet Source

<1 %

29

ijtech.eng.ui.ac.id

Internet Source

<1 %

30

jopr.mpob.gov.my

Internet Source

<1 %

31 pub.epsilon.slu.se <1 %
Internet Source

32 worldwidescience.org <1 %
Internet Source

33 Husna Sarirah Husin, Nurnasuha Amar, Aznida Abu Bakar Sajak, Mohd Sallehin Mohd Kassim. "Distribution map of oil palm fresh fruit bunch using LiDAR*", 2021 12th International Conference on Information and Communication Systems (ICICS), 2021
Publication

34 kindai.repo.nii.ac.jp <1 %
Internet Source

35 Melissa Bridges, W. Brien Henry, Dale L. Shaner, R. Khosla, Phil Westra, Robin Reich. "Spatial Variability of Atrazine and Metolachlor Dissipation on Dryland No-tillage Crop Fields in Colorado", Journal of Environmental Quality, 2008
Publication

Exclude quotes On

Exclude matches Off

Exclude bibliography On